

ST21 (A498)

PARTS CATALOG

INTRODUCTION

This chapter instructs you the numbers and names of these parts on this machine.

INDEX to PARTS CATALOG

1. Exterior (A498)	2	11. Drive and Electrical I(A498)	22
2. Turn Gate (A498)	4	12. Drive and Electrical II(A498)	24
3. Vertical Transport (A498)	6	13. Main Control Board (A498)	26
4. Diagonal Transport(A498)	8	14. AC Harness (A498)	30
5. Distribution Transport (A498)	10	15. Upper DC Harness (A498)	32
6. Jogger (A498)	12	16. Lower DC Harness (A498)	34
7. Bin Side Plate Drive (A498)	14	17. Gripper Harness (A498)	36
8. Staple Unit Drive I(A498)	16	18. Decal and Document (A498)	38
9. Staple Unit Drive II(A498)	18		
10. Staple Unit(A498)	20	Parts Index	42

1. EXTERIOR (A498)

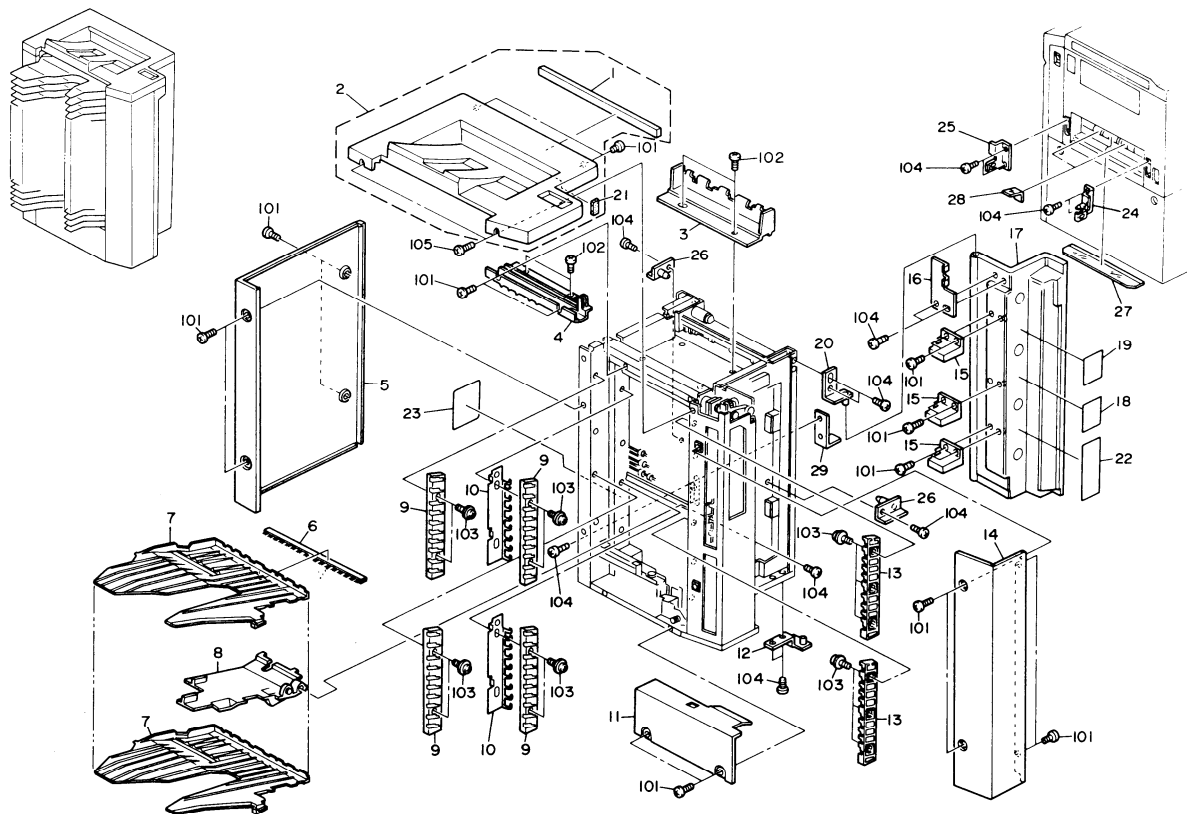

1. EXTERIOR (A498)

Index No.	Part No.	Description	Q'ty Per Assembly
1	5316 3062	Cushion-Cutter	1
2	A498 1241	Proof Tray	1
3	A498 1270	Exit Cover- Proof Tray	1
4	A498 4835	Harness Guide	1
5	A498 1350	Rear Cover	1
6	AA12 0028	Antistatic Brush	18
7	A498 4810	Sorting Bin	20
8	A498 4850	Middle Exit Guide	2
9	A458 1522	Rear Bin Holder	4
10	A498 4860	Grounding Plate	2
11	A498 1370	Bottom Cover	1
12	A498 1061	Lower Hinge Bracket	1
13	A498 4830	Front Bin Holder	2
14	A498 1330	Front Cover	1
15	A498 1791	Front Door Stopper	3
16	A498 1780	Front Door Actuator	1
17	A498 1281	Front Door	1
18	A498 1801	Decal - Misfeed Removal 1	1
19	A498 1820	Decal -Staple Replacement	1
20	A498 1760	Upper Hinge Bracket	1
21	A498 1255	Seal-10x55x10	2
22	A498 1811	Decal - Misfeed Removal 2	1
23	A498 1841	Decal -Dip Switch	1
24	A498 6050	Front Connecting Bracket	1
25	A498 6055	Rear Connecting Bracket	1
26	A498 6060	Locking Bracket	2
27	A498 6070	Upper Entrance Guide Mylar	1
28	A498 6075	Lower Entrance Guide Mylar	2
29	A366 6090	Fixing Bracket	1

Index No.	Part No.	Description	Q'ty Per Assembly
101	0344 0080F	Philips Truss Head Screw - M4x8	
102	0951 4008W	Philips Screw With Flat Washer - M4x8	
103	0951 4006W	Philips Screw With Flat Washer - M4x6	
104	0314 0060W	Philips Pan Head Screw - M4x6	
105	0344 0120F	Philips Truss Head Screw - M4x12	

2. TURN GATE (A498)

Index No.	Part No.	Description	Q'ty Per Assembly
1	5875 2088	Shoulder Screw - M4	2
2	A498 2285	Release Lever Cover	1
3	A498 2281	Right Release Lever	1
4	A498 2368	Guide Plate Cushion	2
5	5053 0447	Bushing - 6mm	2
6	A498 2401	Turn Gate	1
7	A498 2410	Front Stopper - Turn Gate	1
8	A498 2412	Rear Stopper - Turn Gate	1
9	AA06 0273	Turn Gate Spring	1
10	A498 2380	Turn Gate Lever	1
11	A498 2383	Turn Gate Rod	1
12	A498 2356	Vertical Transport Plate - Driven	1
13	5447 2681	Snap Ring	1
14	A498 2375	Turn Gate Solenoid	1
15	A498 2371	Bracket - Turn Gate Solenoid	1
16	A498 2460	Transport Driven Roller	8

Index No.	Part No.	Description	Q'ty Per Assembly
101	0314 0060W	Philips Pan Head Screw - M4x6	
102	0323 0050B	Screw - M3x5	
103	0313 0050W	Philips Pan Head Screw - M3x5	
104	0951 4006W	Philips Screw With Flat Washer - M4x6	
105	0720 0040E	Retaining Ring - M4	
106	0720 0030E	Retaining Ring - M3	

3. VERTICAL TRANSPORT (A498)

Index No.	Part No.	Description	Q'ty Per Assembly
1	AA14 5122	Release Button Shaft	1
2	AA02 0003	Slide Lever Magnet	2
3	A498 2275	Release Button Bracket	1
4	AA06 6111	Release Button Spring	1
5	A498 2271	Release Button	1
6	5403 2075	Stepped Screw	1
7	5053 0447	Bushing - 6mm	8
8	A498 2301	Side Plate - Upper Front	1
9	A498 2343	Lower Entrance Guide	1
10	A498 2345	Shaft Stay	1
11	A498 2331	Upper Entrance Guide	1
12	A498 2435	Vertical Transport Roller	3
13	A498 2245	Stay Plate	2
14	AW02 0013	Inlet Sensor	1
15	A422 5310	Feed-out Motor - DC10W	1
16	A498 5660	Harness - Proof Sensor	1
17	A498 2386	Magnet	1
18	A498 2327	Vertical Transport Plate	1
19	A498 2250	Upper Hinge Bracket	1
20	5447 2681	Snap Ring	1
21	AA12 0027	Antistatic Brush	1
22	A498 2113	Magnet Catch Bracket	2
23	AA06 6112	Spring	1
24	A458 2161	Bushing - 6x8x6	4
25	A498 2465	Exit Driven Roller	2
26	A498 2440	Exit Roller	1
27	A458 2165	Spring - Driven Roller	3
28	5410 1291	Return Lever Pin	1
29	A498 2351	Upper Exit Guide	1
30	A498 2311	Side Plate - Upper Rear	1
31	AB03 0205	Pulley - 31Z	1
32	5442 4495	Slip Clutch	1
33	AA04 3091	Timing Belt -861P3M6	1
34	AB03 0073	Pulley - 31Z	2
35	AB03 0072	Pulley - 31Z	1

Index No.	Part No.	Description	Q'ty Per Assembly
36	A498 2390	Idle Roller	2
37	AB01 7171	Gear And Pulley - 50Z/14Z	1
38	A498 2255	Lower Hinge Bracket	1
39	A498 2349	Small Entrance Guide	1
40	A498 2336	Inner Release Lever	1
101	0314 0060W	Philips Pan Head Screw - M4x6	
102	0951 4006W	Philips Screw With Flat Washer - M4x6	
103	0313 0050W	Philips Pan Head Screw - M3x5	
104	0720 0040E	Retaining Ring - M4	
105	0720 0030E	Retaining Ring - M3	
106	1105 0196	Harness Clamp	
107	0701 0060W	Flat Washer - M6	
108	0574 0040E	Hexagon Headless Set Screw - M4x4	
109	0353 0040F	Philips Pan Head Bind Screw - M3x4	

4. DIAGONAL TRANSPORT (A498)

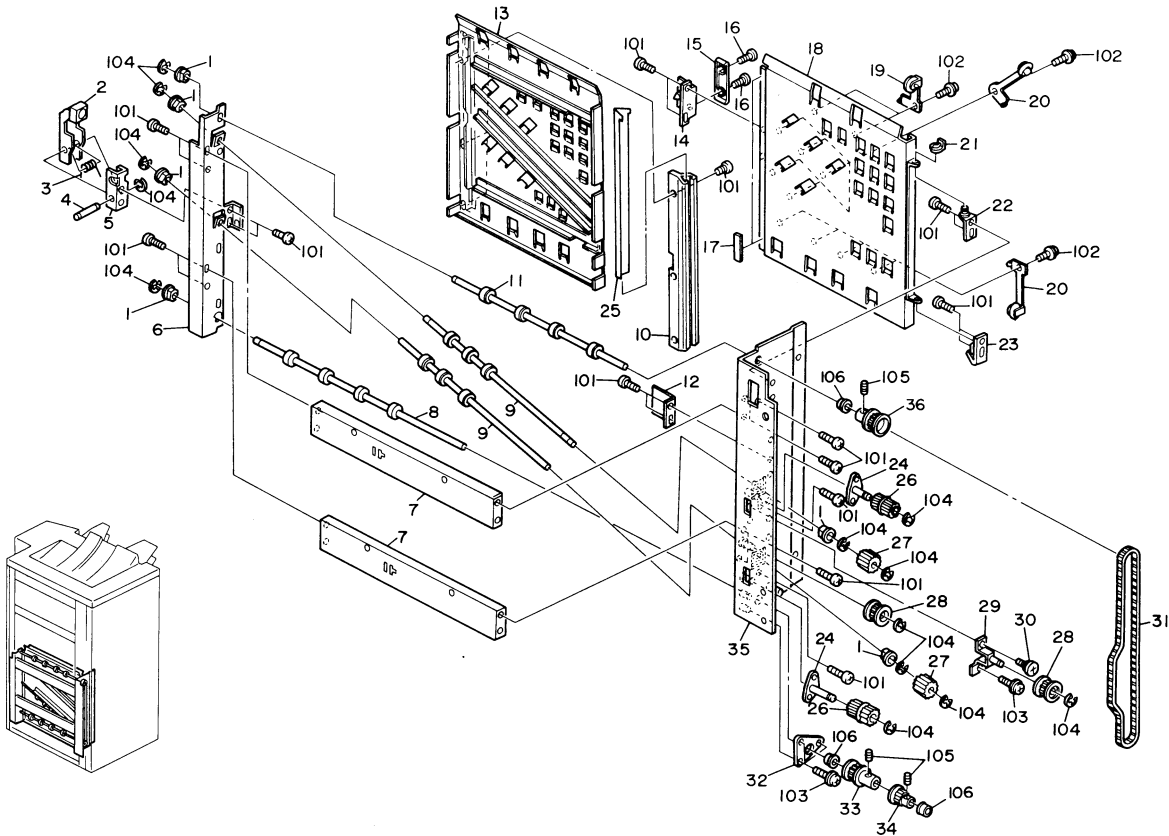

4. DIAGONAL TRANSPORT (A498)

Index No.	Part No.	Description	Q'ty Per Assembly
1	AA08 0071	Bushing-6x10x6	6
2	A498 2271	Release Button	1
3	AA06 6111	Release Button Spring	1
4	AA14 5122	Release Button Shaft	1
5	A498 2275	Release Button Bracket	1
6	A498 2201	Front Side Plate - Diagonal	1
7	A498 2245	Stay Plate	2
8	A498 2420	Horizontal Transport Roller	1
9	A498 2431	Diagonal Transport Roller	2
10	A498 2218	Diagonal Transport Stopper	1
11	A498 2435	Vertical Transport Roller	1
12	A498 2265	Spring Plate	1
13	A498 2216	Diagonal Transport Plate-Drive	1
14	A498 2281	Right Release Lever	1
15	A498 2285	Release Lever Cover	1
16	5875 2088	Shoulder Screw-M4	2
17	A498 2266	Cushion-8x40	2
18	A498 2160	Diagonal Transport Plate-Driven	1
19	A498 2450	Entrance Driven Roller	2
20	A498 2455	Diagonal Driven Roller	9
21	5447 2681	Snap Ring	1
22	A498 2250	Upper Hinge Bracket	1
23	A498 2255	Lower Hinge Bracket	1
24	A498 2242	Tightner	2
25	A498 2219	Myiar -Diagonal Transport Stopper	1
26	AB01 7170	Idle Gear 36Z/24Z	2
27	AB01 0046	Gear-36Z	2
28	5214 1811	Idle Pulley -202	2
29	A498 2248	Tightner - Diagonal Drive	1
30	5403 2075	Stepped Screw	1
31	AA04 3093	Timing Belt - 825P3M6	1
32	A498 2240	Support Plate - Transport Roller	1
33	AB03 0201	Pulley -242	1
34	AB03 0029	Pulley - 20T	1
35	A498 2211	Rear Side Plate - Diagonal	1

Index No.	Part No.	Description	Q'ty Per Assembly
36	AB03 0203	Pulley - 26Z	1
101	0314 0060W	Philips Pan Head Screw - M4x6	
102	0951 3005W	Philips Screw with Flat Washer - M3x5	
103	0951 4006W	Philips Screw With Flat Washer - M4x6	
104	0720 0040E	Retaining Ring - M4	
105	0574 0040E	Hexagon Headless Set Screw - M4x4	
106	0805 3145	Ball Bearing - 6x12x4mm	

5. DISTRIBUTION TRANSPORT (A498)

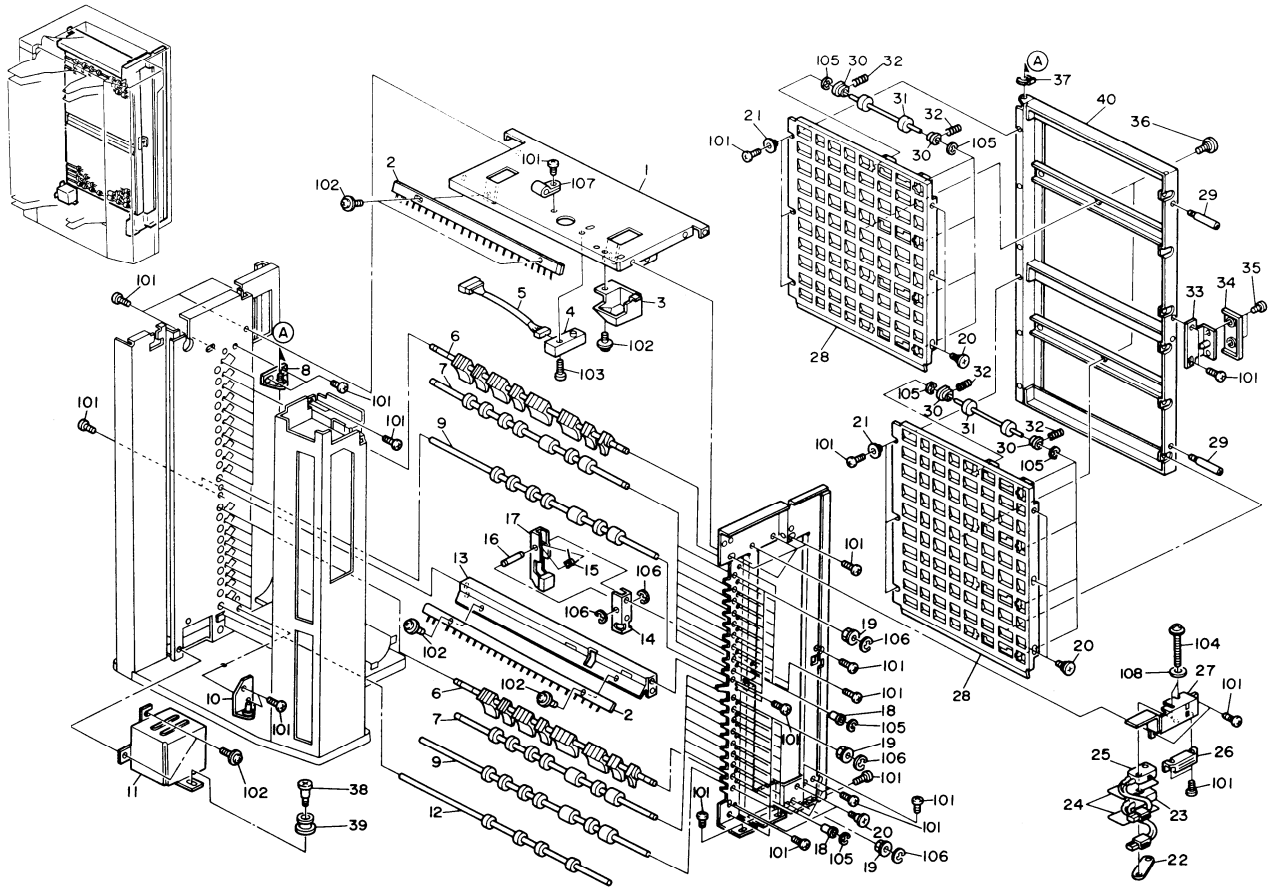

5. DISTRIBUTION TRANSPORT (A498)

Index No.	Part No.	Description	Q'ty Per Assembly
1	A498 1131	Top Stay Plate	1
2	AA12 0027	Antistatic Brush	2
3	A498 4845	Upper Exit Guide - Small	1
4	AW02 0025	Lower Bin/Jam Sensor	1
5	A498 5650	Harness - Upper Bin/Jam Sensor	1
6	A498 3121	Bin Gate	20
7	A498 3155	Distribution Transport Roller - 368mm	18
8	A498 3141	Upper Hinge Bracket	1
9	A498 3150	Distribution Transport Roller - 433mm	2
10	A498 3146	Lower Hinge Bracket	1
11	A498 1756	Main Motor Cover	1
12	A498 2425	Lower Distribution Roller	1
13	A498 1141	Middle Stay	1
14	A498 2275	Release Button Bracket	1
15	AA06 6111	Release Button Spring	1
16	AA14 5122	Release Button Shaft	1
17	A498 2271	Release Button	1
18	5840 2416	Bushing - Pinch Roller	40
19	AA08 0071	Bushing - 6x10x6	40
20	5403 2075	Stepped Screw	7
21	A498 3113	Spacer -4.1x6x3.2	6
22	5056 0509	Nut Plate - Microswitch	1
23	A498 5240	Front Door Switch - AC	1
24	A498 5260	Insulating Sheet	2
25	A498 5250	Front Door Switch - DC	1
26	5054 0536	Magnet Catch Ass'y	1
27	A498 5210	Bracket - Front Door Switch	1
28	A498 3111	Distribution Guide Plate	2
29	A469 3350	Guide Stud	2
30	A458 2161	Bushing - 6x8x6	16
31	A498 3160	Vertical Driven Roller	8
32	A458 2165	Spring - Driven Roller	16
33	A498 3116	Release Lever	1
34	A498 2285	Release Lever Cover	1
35	5875 2088	Shoulder Screw - M4	1

Index No.	Part No.	Description	Q'ty Per Assembly
36	A498 3118	Stepped Screw - M4	2
37	5447 2681	Snap Ring	1
38	5403 6246	Stepped Screw - Cleaning	1
39	5937 2114	Bushing - Driving Side Plate	1
40	A498 3101	Distribution Transport Frame	1
101	0314 0060W	Philips Pan Head Screw - M4x6	
102	0951 4006W	Philips Screw With Flat Washer - M4x6	
103	0313 0160W	Philips Pan Head Screw - M3x16	
104	0951 3030W	Philips Screw With Washer - M3x30	
105	0720 0030E	Retaining Ring - M3	
106	0720 0040E	Retaining Ring - M4	
107	1105 0008	Nylon Clip - 2N	
108	0701 0030G	Flat Washer - M3	

6. JOGGER (A498)

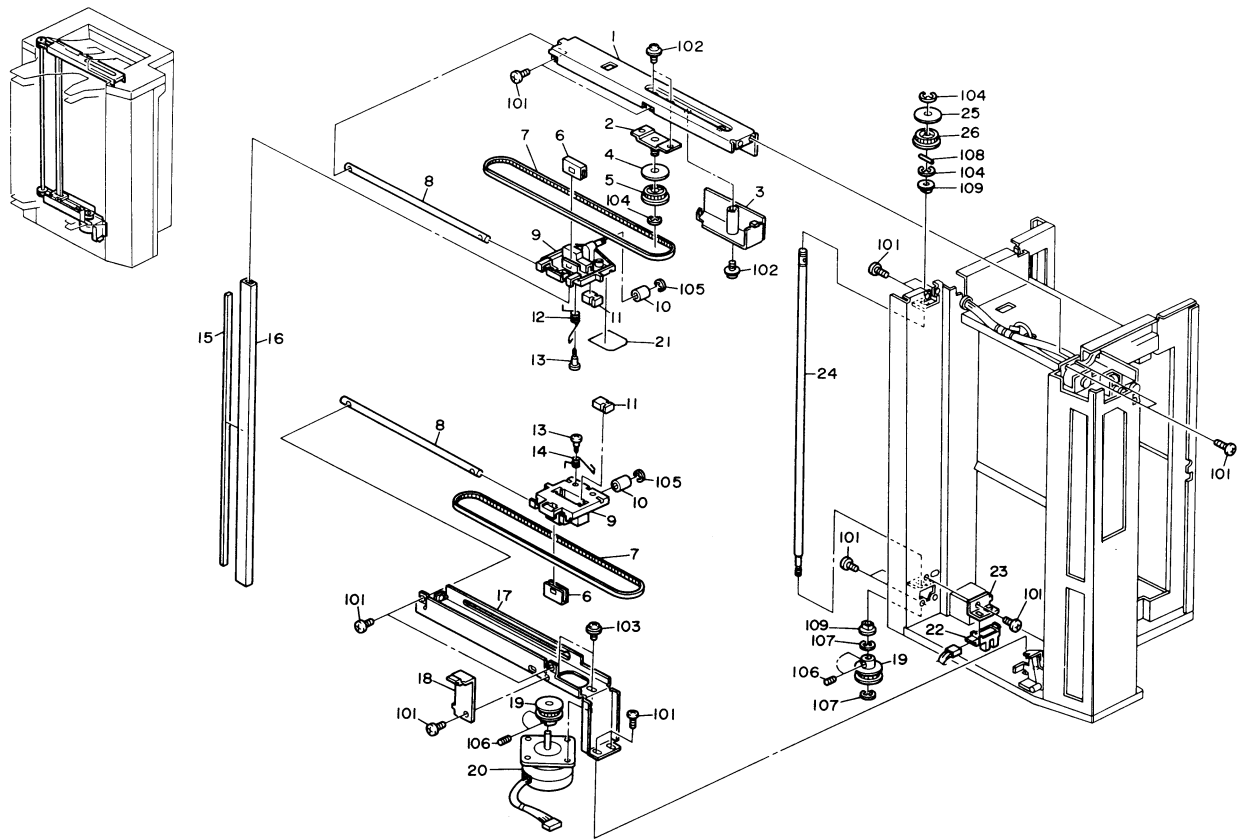

6. JOGGER (A498)

Index No.	Part No.	Description	Q'ty Per Assembly
1	A498 4105	Upper Jogger Bracket	1
2	A498 4160	Pulley Bracket	1
3	A498 4840	Upper Exit Guide	1
4	A498 4158	Pulley Flange	1
5	AB03 0215	Pulley - 36Z	1
6	A498 4140	Jogger Timing Belt Stopper	2
7	AA04 3097	Timing Belt - 4x580	2
8	AA14 0303	Jogger Slide Shaft	2
9	A498 4110	Jogger Plate Holder	2
10	A498 4120	Jogger Holder Roller	2
11	A498 4135	Rubber Shaft Spacer	2
12	AA06 6121	Upper Jogger Spring	1
13	A498 4145	Shoulder Screw - M3	2
14	AA06 6120	Lower Jogger Spring	1
15	A498 4178	Plate Cushion	1
16	A498 4175	Jogger Plate	1
17	A498 4100	Jogger Bracket	1
18	A498 1770	Bottom Cover Bracket	1
19	AB03 0213	Pulley - 36Z	2
20	AX04 0036	Motor - DC 8.16W	1
21	A498 4115	Jogger Holder Seal - 32x41	1
22	5216 5245	Photointerruptor - IL-G-3P-S3T2-E	1
23	A498 4185	Sensor Bracket	1
24	AA14 0304	Jogger Pulley Shaft	1
25	A498 4158	Pulley Flange	1
26	AB03 0215	Pulley - 36Z	1

Index No.	Part No.	Description	Q'ty Per Assembly
101	0314 0060W	Philips Pan Head Screw - M4x6	
102	0951 4006W	Philips Screw With Flat Washer - M4x6	
103	0951 4008W	Philips Screw With Flat Washer - M4x8	
104	0720 0060E	Retaining Ring - M6	
105	0720 0030E	Retaining Ring - M3	
106	0574 0040E	Hexagon Headless Set Screw - M4x4	
107	0720 0040E	Retaining Ring - M4	
108	0632 0160G	Parallel Pin - M2x16	
109	0805 3386	Bushing - 8mm	

7. BIN SIDE PLATE DRIVE (A498)

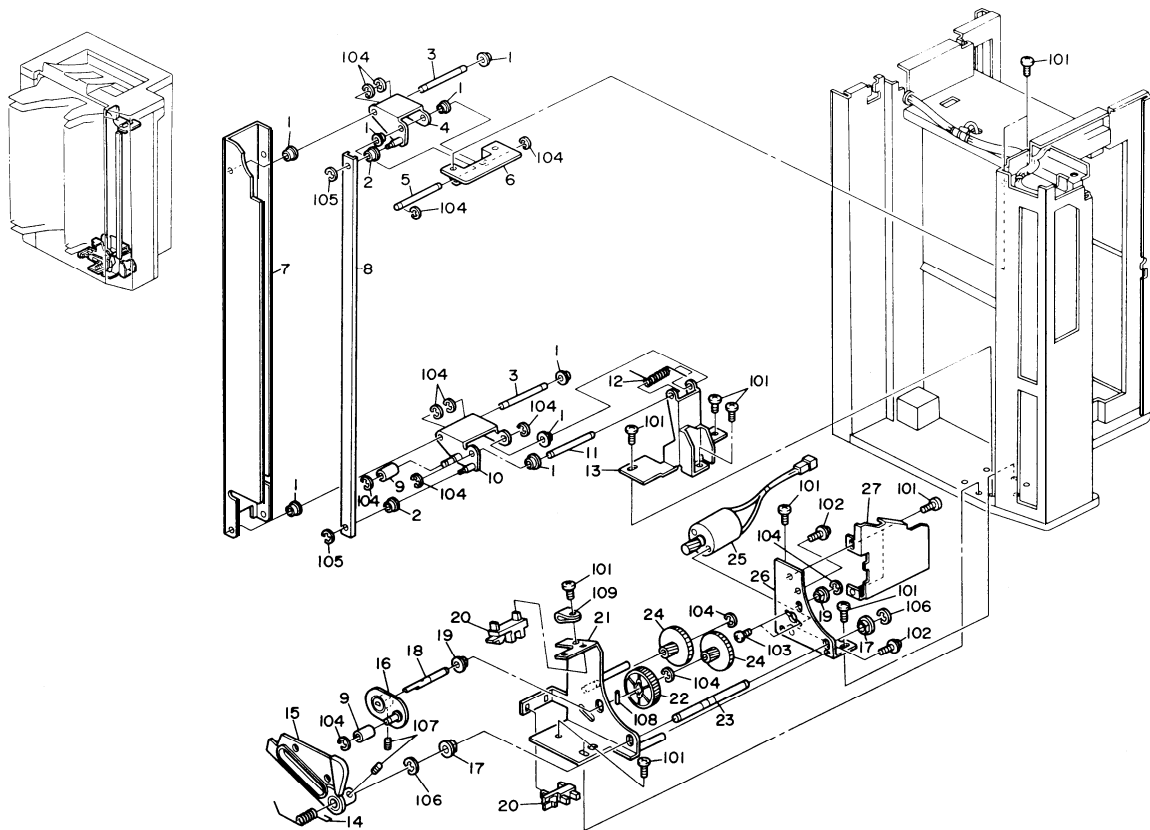

7. BIN SIDE PLATE DRIVE (A498)

Index No.	Part No.	Description	Q'ty Per Assembly
1	AA08 0072	Bushing-6x10x3	8
2	A469 4465	Reverse Roller	2
3	AA14 5125	Inner Side Fence Shaft	2
4	A498 4765	Upper Drive Link	1
5	AA14 5127	Upper Side Fence Shaft	1
6	A498 4780	Side Plate Fixing Bracket	1
7	A498 4770	Bin Side Plate	1
8	A498 4775	Support Link	1
9	5203 1091	Collar	2
10	A498 4760	Lower Driveling	1
11	AA14 5126	Lower Side Fence Shaft	1
12	AA06 6116	Side Fence Spring	1
13	A498 4755	Side Plate Lower Bracket	1
14	AA06 6115	Cam Support Spring	1
15	A498 4730	Plate Cam	1
16	A498 4720	Plate Guide Cam	1
17	5053 0223	Bushing-8mm	2
18	AA14 8238	Side Fence Shaft	1
19	5053 0447	Bushing -6mm	2
20	AW02 0006	Photointerruptor - EE-SX460-P2	2
21	A498 4710	Cam Plate Bracket	1
22	AB01 0047	Gear-72Z	1
23	AA14 8239	Drive Camshaft	1
24	AB01 7172	Double Gear-20/72Z	2
25	AX04 0034	Motor - DC 2.2W	1
26	A498 4707	Motor Bracket	1
27	A498 4740	Motor Cover	1

Index No.	Part No.	Description	Q'ty Per Assembly
101	0314 0060W	Philips Pan Head Screw - M4x6	
102	0951 4006W	Philips Screw With Flat Washer - M4x6	
103	0800 0072	Philips Pan Head Screw - M2.6x4	
104	0720 0040E	Retaining Ring - M4	
105	0720 0030E	Retaining Ring - M3	
106	0720 0060E	Retaining Ring - M6	
107	0574 0040E	Hexagon Headless Set Screw - M4x4	
108	0632 0140G	Parallel Pin	
109	1105 0008	Nylon Clip - 2N	

8. STAPLE UNIT DRIVE I (A498)

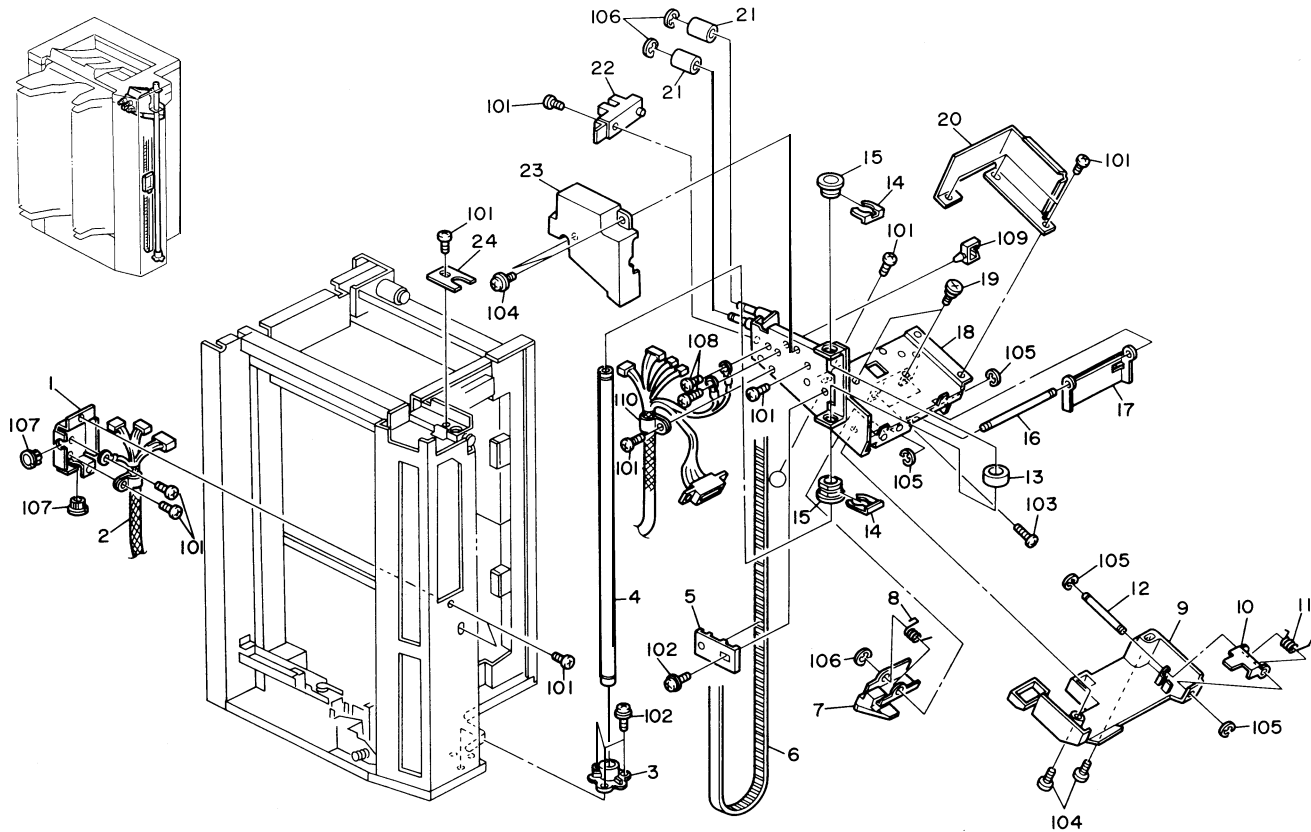

8. STAPLE UNIT DRIVE I (A498)

Index No.	Part No.	Description	Q'ty Per Assembly
1	A498 4588	Flame Connector Cover	1
2	A498 5630	Gripper Harness	1
3	A498 4380	Guide Rod Holder	1
4	A498 4375	Guide Rod - Staple Unit	1
5	A498 4530	Timing Belt Clamp	1
6	AA04 3095	Timing Belt - 10x1788	1
7	A498 4535	Stapler Release Lever	1
8	AA06 6113	Release Lever Spring	1
9	A498 4575	Gripper Harness Cover	1
10	A498 4580	Shutter Connect Stopper	1
11	AA06 6114	Shutter Stopper Spring	1
12	AA14 5124	Shutter Stopper Spring	1
13	A007 1848	Guide Rod Cleaner	1
14	A498 4525	Bushing Stopper	2
15	A498 4520	Bushing - 18x26x10	1
16	AA14 5123	Connector Shutter Shaft	1
17	A498 4540	Connector Shutter	1
18	A498 4510	Stapler Bracket	1
19	A498 4542	Shoulder Screw - M6	2
20	A498 4590	Lower Entrance Guide - Stapler	1
21	5203 1091	Collar	2
22	AW02 0014	Photo Sensor	1
23	A498 4585	Connector Cover	1
24	A498 4370	Fixing Plate	1

Index No.	Part No.	Description	Q'ty Per Assembly
101	0314 0060W	Philips Pan Head Screw - M4x6	
102	0951 4008W	Philips Screw With Flat Washer - M4x8	
103	0313 0100W	Philips Pan Head Screw - M3x10	
104	0951 4006W	Philips Screw With Flat Washer - M4x6	
105	0720 0030E	Retaining Ring - M3	
106	0720 0040E	Retaining Ring - M4	
107	1106 0411	Bushing -11.5mm	
108	0434 0060W	Tapping Screw - M4x6	
109	1105 0196	Harness Clamp	
110	1105 0010	Nylon Clip - 6N	

9. STAPLE UNIT DRIVE II (A498)

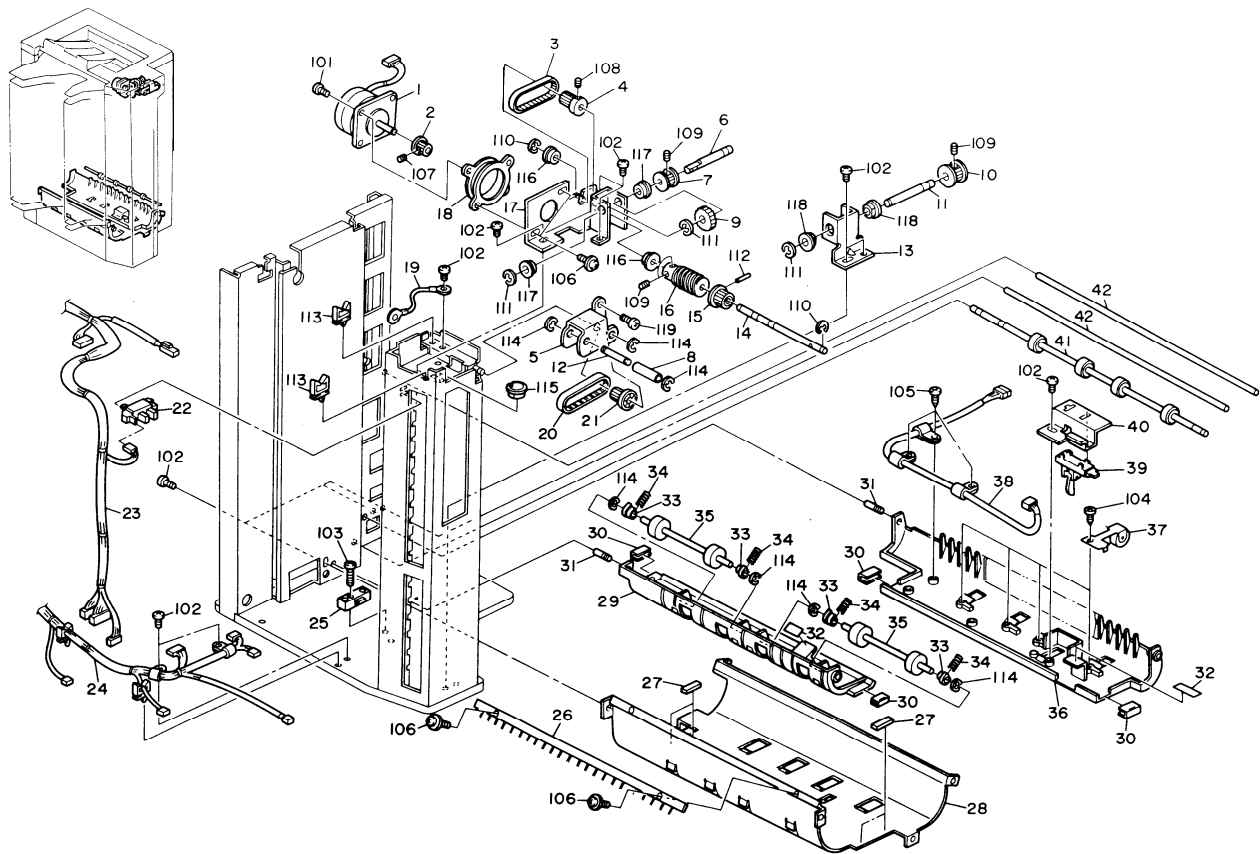

9. STAPLE UNIT DRIVE II (A498)

Index No.	Part No.	Description	Q'ty Per Assembly
1	AX04 0025	Staple Unit Motor	1
2	AB03 0211	Pulley - 20Z	1
3	AA04 3094	Timing Belt - 6x144	1
4	AB03 0212	Pulley - 15Z	1
5	A498 4360	Knob Tension Bracket	1
6	AA14 8236	Upper Pulley Shaft	1
7	AB03 0072	Pulley - 31Z	1
8	A498 4365	Tension Roller	1
9	A469 4104	Gear - 25Z	1
10	AB03 0209	Pulley - 20Z	1
11	AA14 8237	Lower Pulley Shaft	1
12	AA14 5030	Knob Tension Shaft	1
13	A498 4320	Puny Bracket	1
14	AA14 8235	Warm Gear Shaft	1
15	AB03 0219	Pulley - 30Z	1
16	A469 4103	Worm Gear - 2Z	1
17	A498 4310	Motor Bracket	1
18	A469 5350	Motor Damper	1
19	A469 5465	Grounding Wire	1
20	AA04 3096	Timing Belt - 4x160	1
21	A498 4350	Knob & Pulley - 20Z	1
22	AW02 0007	Photointerrupter - ON1531A2-(A)4	1
23	A498 5610	Upper DC Harness	1
24	A498 5615	Lower DC Harness	1
25	AW02 0026	Upper Bin/Jam Sensor	1
26	AA12 0027	Antistatic Brush	1
27	AA02 0003	Slide Lever Magnet	2
28	A498 2101	Lower Guide Plate - Drive	1
29	A498 2116	Lower Left Guide	1
30	A498 2113	Magnet Catch Bracket	4
31	5410 1291	Return Lever Pin	1
32	A498 2118	Seal - 24x11	2
33	A458 2161	Bushing - 6x8x6	4
34	A458 2165	Spring - Driven Roller	4
35	A498 3160	Vertical Driven Roller	2

Index No.	Part No.	Description	Q'ty Per Assembly
36	A498 2111	Lower Right Guide	1
37	A498 2460	Transport Driven Roller	4
38	A498 5640	Harness - Sorter Entrance Sensor	1
39	AW02 0013	Inlet Sensor	1
40	A498 2114	Bracket - Sorter Entrance Guide	1
41	A498 2420	Horizontal Transport Roller	1
42	A498 1146	Shaft	2
101	0314 0080W	Philips Pan Head Screw - M4x8	
102	0314 0060W	Philips Pan Head Screw - M4x6	
103	0313 0160W	Philips Pan Head Screw - M3x16	
104	0433 0064W	Tapping Screw - M3x6	
105	0434 0102W	Tapping Screw - M4x10	
106	0951 4006W	Philips Screw With Flat Washer - M4x6	
107	0574 0040E	Hexagon Headless Set Screw - M4x4	
108	0574 0060E	Hexagon Headless Set Screw - M4x6	
109	0574 0040E	Hexagon Headless Set Screw - M4x4	
110	0720 0040E	Retaining Ring - M4	
111	0720 0060E	Retaining Ring - M6	
112	0632 0140G	Parallel Pin	
113	1105 0197	Wire Saddle	
114	0720 0030E	Retaining Ring - M3	
115	1106 0310	Bushing	
116	0805 3145	Ball Bearing - 6x12x4mm	
117	0805 3291	Bail Bearing - 8x16x5mm	
118	0805 3386	Bushing - 8mm	
119	0314 0100W	Philips Pan Head Screw - M4x10	

10. STAPLE UNIT (A498)

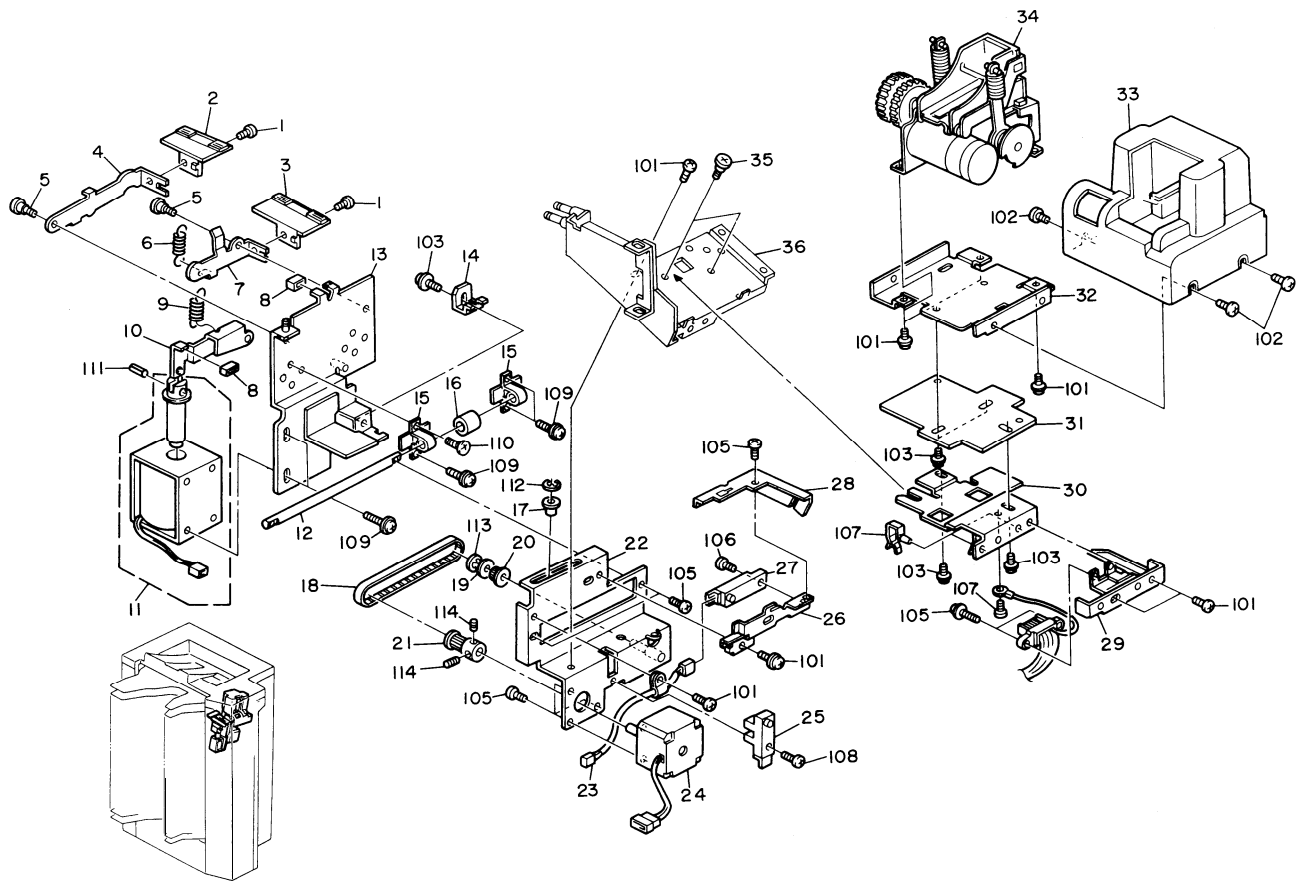

10. STAPLE UNIT (A498)

Index No.	Part No.	Description	Qty Per Assembly
1	5353 4258	Screw - Slider	2
2	A498 4640	Upper Gripper Arm	1
3	A498 4655	Lower Gripper Arm	1
4	A498 4635	Upper Arm Link	1
5	C201 5125	Shoulder Screw-M4	2
6	AA06 0275	Arm Spring	1
7	A498 4650	Lower Arm Link	1
8	A498 4625	Arm Cushion	2
9	AA06 0274	Solenoid Spring	1
10	A498 4620	Solenoid Link	1
11	A498 4615	Grip Solenoid	1
12	AA14 0305	Slider Shaft	1
13	A498 4610	Slider Side Plate - Transport	1
14	A498 4670	Slider Stopper	1
15	A498 4623	Slider Bushing	2
16	A498 4675	Slider Shaft Cleaner	1
17	AA08 0074	Bushing-4x6x6	1
18	AA04 3098	Timing Belt-4x190	1
19	A498 4665	Pulley Flange	1
20	AB03 0218	Pulley-15Z	1
21	AB03 0216	Pulley-15Z	1
22	A498 4605	Slider Side Plate	1
23	A498 5620	Paper Sensor Harness	1
24	AX04 0035	Motor - DC 2.4W	1
25	AW02 0014	Photo Sensor	1
26	A498 4685	Sensor Bracket	1
27	A010 5700	Sensor	1
28	A498 4690	Stapler Entrance Guide	1
29	A498 4565	Stapler Connect Holder	1
30	A498 4555	Stapler Fixing Bracket	1
31	A498 4550	Stapler Fixing Plate	1
32	A498 4545	Stapler Bracket	1
33	A498 4595	Stapler Cover	1
34	AJ01 1002	Stapler Unit	1
35	A498 4542	Shoulder Screw-M6	2

Index No.	Part No.	Description	Qty Per Assembly
36	A498 4510	Stapler Bracket	1
101	0314 0060W	Philips Pan Head Screw - M4x6	
102	0344 0080F	Philips Truss Head Screw - M4x8	
103	0951 4006W	Philips Screw With Flat Washer - M4x6	
104	0951 3008W	Philips Screw with Flat Washer - M3x8	
105	0313 0050W	Philips Pan Head Screw - M3x5	
106	0313 0100W	Philips Pan Head Screw - M3x10	
107	1105 0200	Clamp	
108	0314 0100W	Philips Pan Head Screw - M4x10	
109	0951 3006W	Philips Screw With Flat Washer - M3x6	
110	0951 3014W	Philips Screw With Flat Washer - M3	
111	0623 0120E	Spring Pin - 3x12mm	
112	0720 0030E	Retaining Ring - M3	
113	0720 0040E	Retaining Ring - M4	
114	0574 0040E	Hexagon Headless Set Screw - M4x4	

11. DRIVE AND ELECTRICAL I (A498)

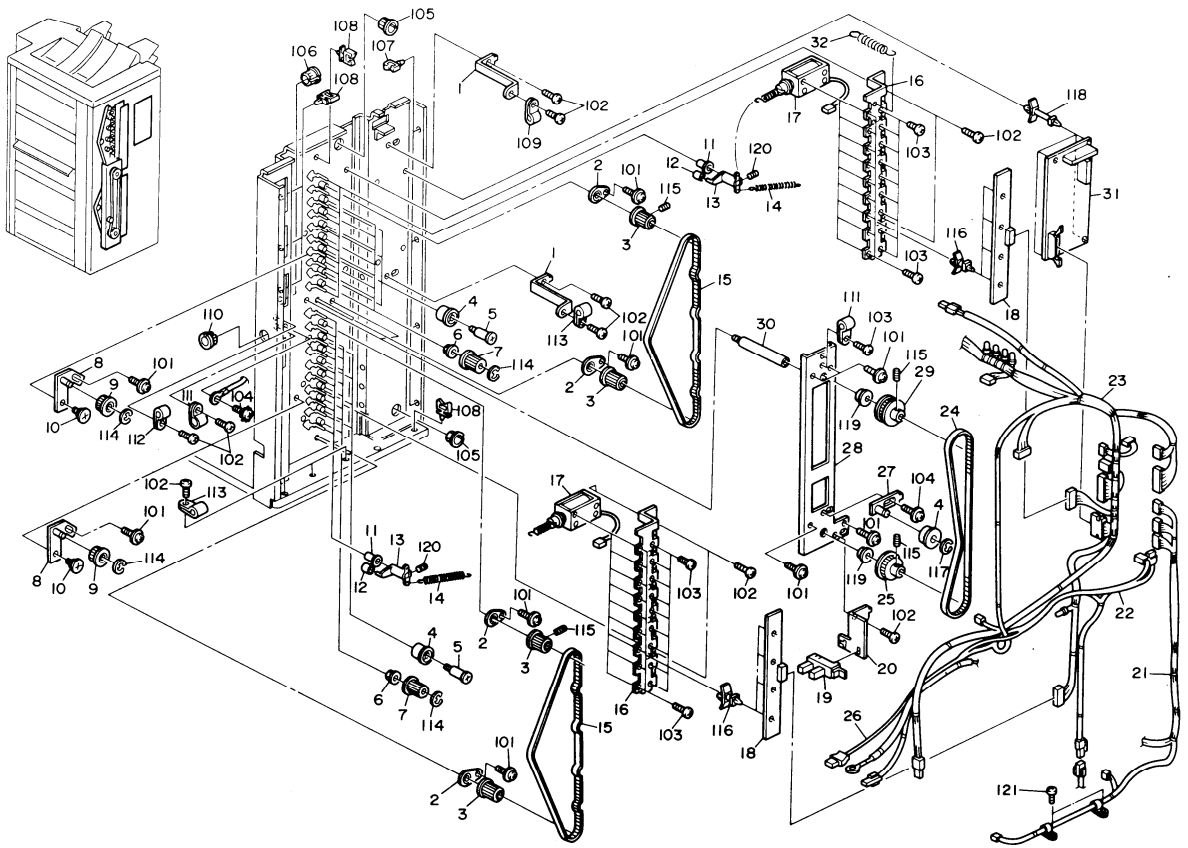

11. DRIVE AND ELECTRICAL I (A498)

Index No.	Part No.	Description	Q'ty Per Assembly
1	A469 3280	Board Support Bracket - Short	2
2	A458 1561	Holding Plate And Bearing - 6x12x4	4
3	A458 3132	Pulley - 17Z	4
4	5887 4185	Idler Pulley	3
5	5887 4195	Stopper Screw	2
6	AA08 0071	Bushing - 6x10x6	2
7	AB03 0030	Pulley - 17T	2
8	A458 3231	tightner	2
9	AB03 0207	Idle Gear - 20Z	2
10	5403 2075	Stepped Screw	2
11	5840 2416	Bushing - Pinch Roller	20
12	A458 2251	Cushion - Bin Solenoid Lever	20
13	A458 2232	Bin Solenoid Lever	20
14	5887 4166	Return Spring - Turn Pawl	20
15	A458 3431	timing Belt - 699P3M6	2
16	A498 3132	Solenoid Bracket	2
17	A498 5400	Bin Solenoid	18
18	A469 5130	Bin Solenoid Board	2
19	5216 5245	Photointerruptor - IL-G-3 P-S3T2-E	1
20	A498 1521	Timing Sensor Bracket	1
21	A498 5615	Lower DC Harness	1
22	A498 5600	AC Harness	1
23	A498 5610	Upper DC Harness	1
24	AA04 3091	Timing Belt -861P3M6	1
25	A458 3142	Pulley - 39Z	1
26	AW03 0014	Fiber Cable -800	1
27	A458 3211	Tightner	1
28	A498 1511	Support Bracket	1
29	A458 3141	Pulley - 39Z	1
30	A498 1516	Support Bracket Stay	2
31	A498 5100	Main Control Board	1
32	5887 4167	Holder Spring - Turn Pawl	1

Index No.	Part No.	Description	Q'ty Per Assembly
101	0951 4006W	Philips Screw With Flat Washer - M4x6	
102	0314 0060W	Philips Pan Head Screw - M4x6	
103	0313 0050W	Philips Pan Head Screw - M3x5	
104	0801 1185	Philips Truss Head Screw - M4x8	
105	1106 0310	Bushing	
106	1106 0411	Bushing -11.5mm	
107	1105 0197	Wire Saddle	
108	1105 0196	Harness Clamp	
109	1105 0016	Nylon Clip - 4N	
110	1106 0459	Bushing - 20.2mm	
111	1105 0005	Nylon Clip - 3N	
112	1105 0009	Nylon Clip - 5N	
113	1105 0008	Nylon Clip - 2N	
114	0720 0040E	Retaining Ring - M4	
115	0574 0040E	Hexagon Headless Set Screw - M4x4	
116	1105 0161	Locking Support	
117	0720 0060E	Retaining Ring - M6	
118	1105 0134	Locking Support	
119	0805 3145	Ball Bearing - 6x12x4mm	
120	0573 0040E	Hexagon Headless Set Screw - M3x4	
121	0313 0060W	Philips Pan Head Screw - M3x6	

12. DRIVE AND ELECTRICAL II (A498)

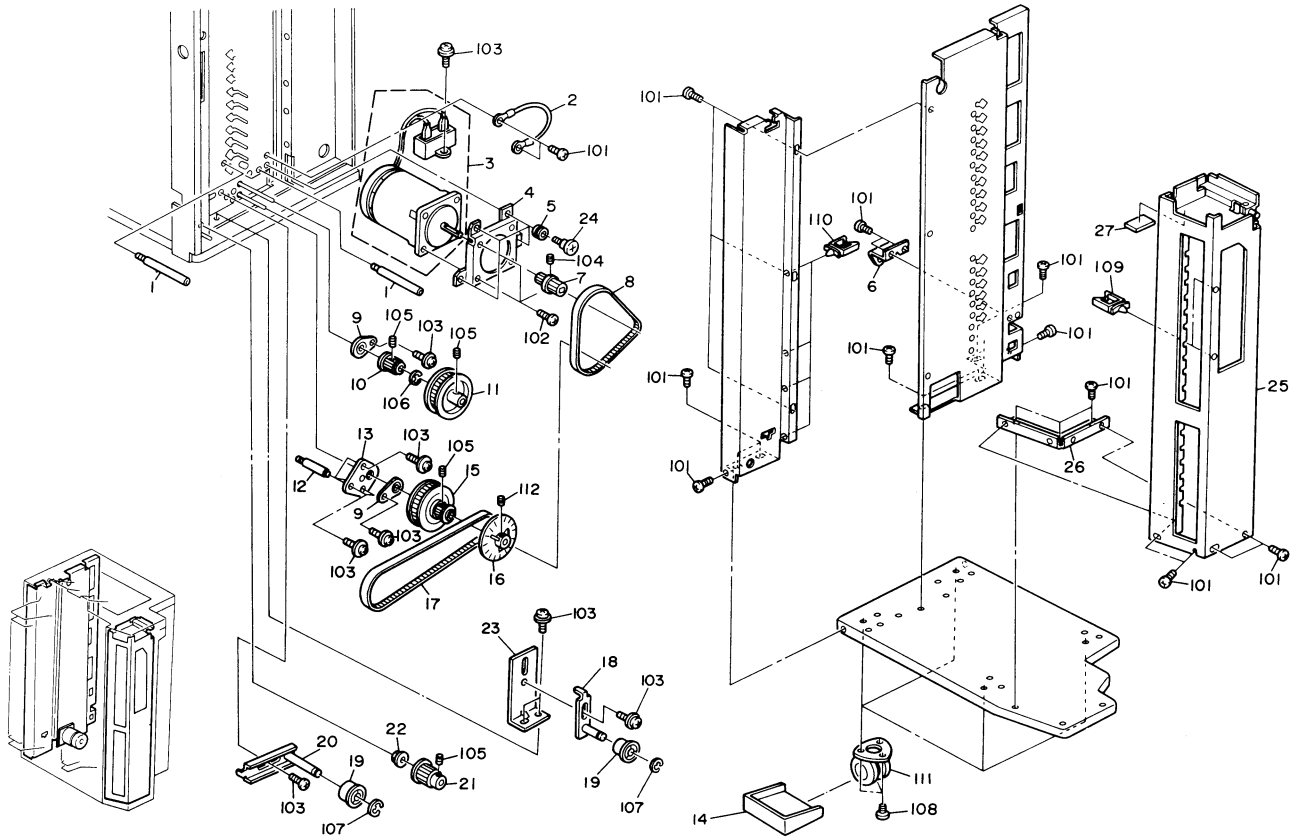

12. DRIVE AND ELECTRICAL II (A498)

Index No.	Part No.	Description	Q'ty Per Assembly
1	A498 1516	Support Bracket Stay	2
2	A469 5465	Grounding Wire	1
3	A02 0052	Main Motor	1
4	A498 1451	Main Motor Bracket	1
5	5937 2114	Bushing - Driving Side Plate	4
6	A498 2298	Support Bracket-Transpot Roller	1
7	AB03 3027	Pulley-15/18Z	1
8	AA04 3090	Timing Belt-330P3M6	1
9	A458 1561	Holding PlateAnd Bearing-6x12x4	1
10	A458 3132	Pulley-17Z	1
11	A458 3121	Pulley-50Z	1
12	A458 1231	Stud	3
13	A498 2121	Drive Support Plate	1
14	A498 6085	Caster Stopper	1
15	A458 3151	Pulley-17/50Z	1
16	5420 1087	Perforation Disk	1
17	AA04 3081	Timing Belt-489P3M6	1
18	A498 1477	Tightner	1
19	5887 4185	Idler Pulley	2
20	A458 3221	tightner	1
21	AB03 0029	Pulley-20T	1
22	AA08 0071	Bushing-6x10x6	1
23	A498 1485	Tightner Bracket	1
24	5403 6246	Stepped Screw - Cleaning	4
25	A498 4390	Front Side Plate	1
26	A498 4385	Frame Fixing Bracket	1
27	5215 3860	Cushion	1

Index No.	Part No.	Description	Q'ty Per Assembly
101	0314 0060W	Philips Pan Head Screw - M4x6	
102	0314 0080W	Philips Pan Head Screw - M4x8	
103	0951 4006W	Philips Screw With Flat Washer - M4x8	
104	0574 0060E	Hexagon Headless Set Screw - M4x6	
105	0574 0040E	Hexagon Headless Set Screw - M4x4	
106	0720 0040E	Retaining Ring - M4	
107	0720 0060E	Retaining Ring - M6	
108	0315 0080W	Philips Pan Head Screw - M5x8	
109	1105 0197	Wire Saddle	
110	1105 0196	Harness Clamp	
111	0805 5003	Caster	
112	0575 0060E	Hexagon Headless Set Screw - M5x6	

13. MAIN CONTROL BOARD (A498)

CAPACITOR

SYMBOL NO.	INDEX NO.
C100	147
C101	149
C102	152
C103	152
C104	148
C105	150
C106	145
C107	146
C108	154
C109	154

SYMBOL NO.	INDEX NO.
C110	154
C111	154
C112	153
C113	153
C114	154
C115	154
C116	154
C117	154
C118	154
C119	154

SYMBOL NO.	INDEX NO.
C120	153
C121	153
C122	154
C123	154
C124	154
C125	154
C126	154
C127	154
C128	154
C129	154

SYMBOL NO.	INDEX NO.
C130	151
C131	151
C132	154
C133	154
C134	154
C135	154
C136	154
C137	154
C138	154
C139	154

SYMBOL NO.	INDEX NO.
C140	154
C141	154
C142	154
C143	154
C144	154
C145	154
C146	154
C147	154
C148	154
C149	154

SYMBOL NO.	INDEX NO.
C150	154
C151	154
C152	154
C153	154
C154	154
C155	154
C156	154
C157	154

CONNECTOR

SYMBOL NO.	INDEX NO.
CN100	103
CN110	102
CN120	104
CN130	113
CN140	111
CN150	107
CN160	106
CN170	108
CN180	110
CN185	112

SYMBOL NO.	INDEX NO.
CN190	109
CN195	105

CR

SYMBOL NO.	INDEX NO.
CR100	144

DIODE

SYMBOL NO.	INDEX NO.
D100	120
D101	120

DPS

SYMBOL NO.	INDEX NO.
DPS100	115

HB

SYMBOL NO.	INDEX NO.
HB100	137

IC

SYMBOL NO.	INDEX NO.
IC101	136
IC102	136
IC103	131
IC104	131
IC105	124
IC106	123
IC107	135
IC108	133
IC109	128
IC110	130

SYMBOL NO.	INDEX NO.
(SOCKET)	1
IC111	114
IC112	132
IC113	125
IC114	129
IC115	126
IC116	127
IC117	126
IC118	134
IC119	126

13. MAIN CONTROL BOARD (A498)

LED

SYMBOL NO.	INDEX NO.
LED100	122
LED101	122
LED102	122

OSC

SYMBOL NO.	INDEX NO.
OSC100	138

PC

SYMBOL NO.	INDEX NO.
PC100	121

RERAY

SYMBOL NO.	INDEX NO.
RAY100	139
RAY101	139
RAY102	139
RAY103	141
RAY104	139
RAY107	140

RESISTOR

SYMBOL NO.	INDEX NO.
R100	168
R101	163
R102	168
R103	165
R104	162
R105	162
R106	165
R107	161
R108	162
R109	162

SYMBOL NO.	INDEX NO.
R110	162
R111	170
R112	160
R113	164
R114	155
R115	167
R116	166
R117	170
R118	168
R119	159

SYMBOL NO.	INDEX NO.
R120	162
R121	168
R122	156
R123	167
R124	167
R125	168
R126	168
R127	158
R128	158
R129	167

SYMBOL NO.	INDEX NO.
R130	167
R131	167
R132	167
R133	169
R134	165
R135	165
R136	165
R137	168
R138	168
R139	158

SYMBOL NO.	INDEX NO.
R140	158
R141	158
R142	157
R143	157
R144	157
R145	157
R146	158
R147	158
R148	157
R149	162

SYMBOL NO.	INDEX NO.
R150	165
R151	162
R152	165
R153	157
R154	157
R155	168
R156	168
R157	168
R158	168
R159	168

SYMBOL NO.	INDEX NO.
R160	168
R161	161
R162	168
R163	168
R164	168
R165	168
R166	168
R167	168
R168	168
R169	168

SYMBOL NO.	INDEX NO.
R170	168
R171	168
R172	168
R173	168
R174	168
R175	168
R176	168
R177	168
R178	168
R179	168

SYMBOL NO.	INDEX NO.
R180	168
R181	168
R182	168
R183	168
R184	168
R185	168
R186	168
R187	168
R188	167
R189	167

SYMBOL NO.	INDEX NO.
R190	159
R191	159
R192	165
R193	162
R194	168
R195	168
R196	160

13. MAIN CONTROL BOARD (A498)

SSR

SYMBOL NO.	INDEX NO.
SSR	116

TEST POINT

SYMBOL NO.	INDEX NO.
TP100	101
TP101	101
TP102	101

TRANSISTOR

SYMBOL NO.	INDEX NO.
Q101	117
Q102	117
Q103	117

VR

SYMBOL NO.	INDEX NO.
VR100	143
VR101	143
VR102	142

ZENER DIODE

SYMBOL NO.	INDEX NO.
ZD100	118
ZD101	119

14. AC HARNESS (A498)

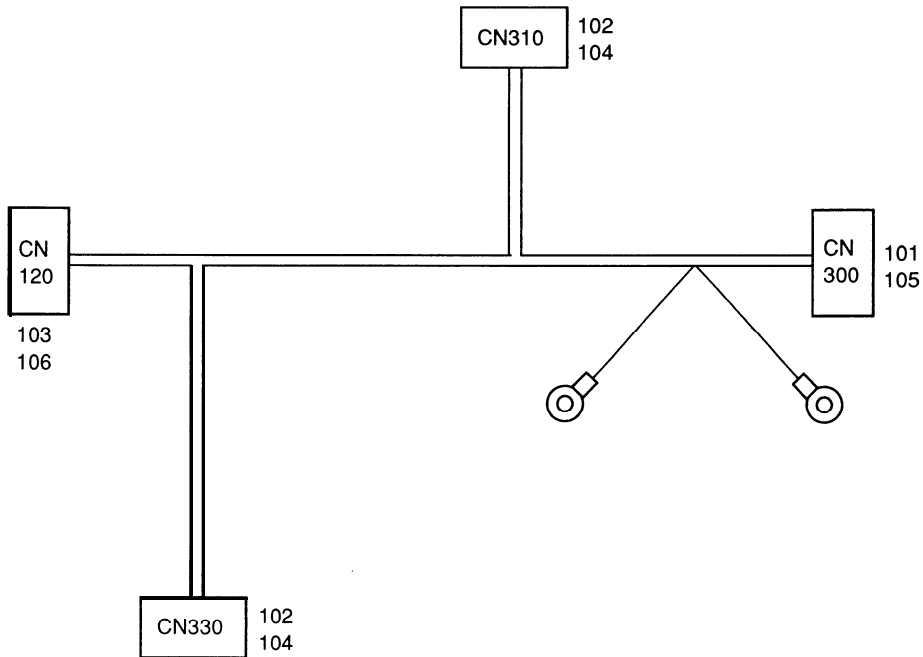

14. AC HARNESS (A498)

Index No.	Part No.	Description	Qty Per Assembly
*	A498 5600	AC Harness	1

Index No.	Part No.	Description	Qty Per Assembly
101	1100 1239	Pin - Mate-N-Lock	
102	1100 1241	Socket - Mate-N-Lock	
103	1100 1247	Terminal	
104	1102 1515	Connector - 2P	
105	1102 1524	Connector - 2P	
106	1102 1896	Connector - 2P	

15. UPPER DC HARNESS (A498)

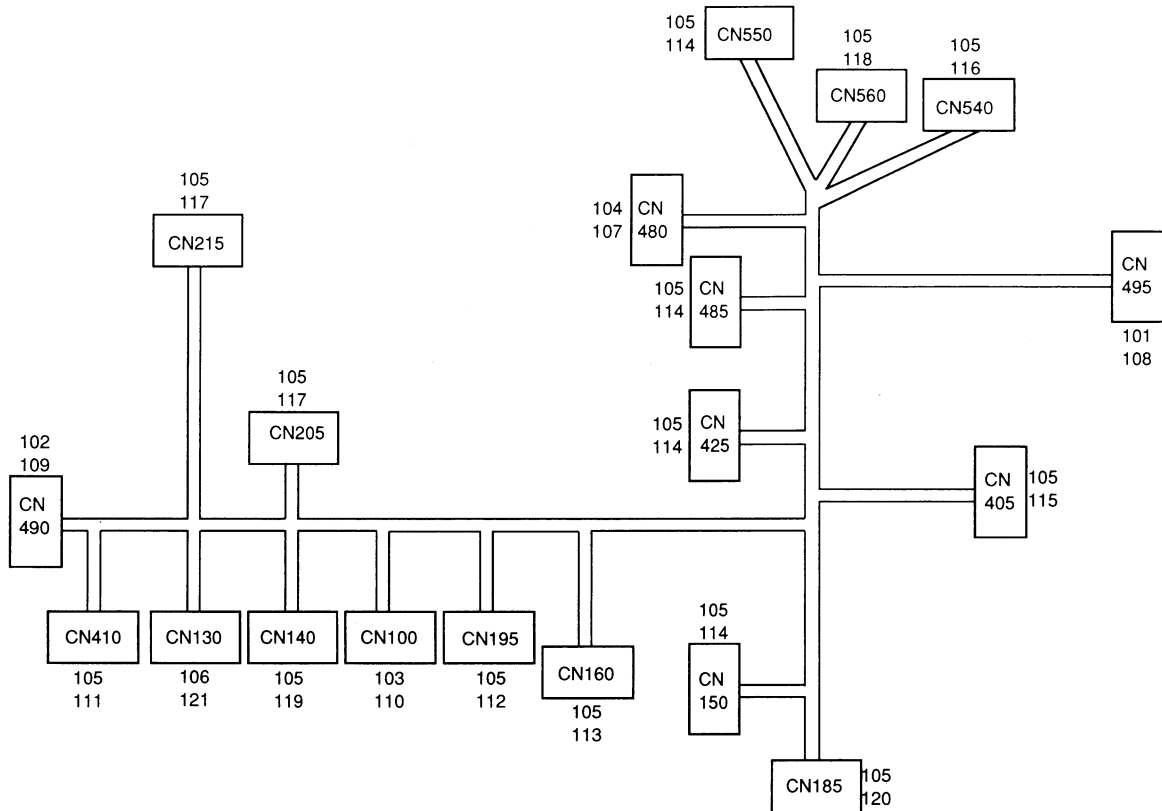

15. UPPER DC HARNESS (A498)

Index No.	Part No.	Description	Q'ty Per Assembly
*	A498 5610	Upper DC Harness	1

Index No.	Part No.	Description	Q'ty Per Assembly
101	1100 1239	Pin - Mate-N-Lock	
102	1100 1241	Socket - Mate-N-Lock	
103	1100 1247	Terminal	
104	1100 1259	Socket - Mate-N-Lock	
105	1100 1329	Socket Contact	
106	1100 1348	Pin Contact	
107	1102 1089	Connector - 3P	
108	1102 1507	Connector - 2P	
109	1102 1517	Connector - 4P	
110	1102 1831	Connector - 4P	
111	1102 1982	Socket Housing-2P	
112	1102 1984	Connector-4P	
113	1102 1985	Connector-5P	
114	1102 1986	Connector-6P	
115	1102 1988	Socket Housing-8P	
116	1102 1990	Socket Housing-10P	
117	1102 1991	Socket Housing-11P	
118	1102 1992	SocketHousing-12P	
119	1102 1994	SocketHousing-14P	
120	1102 1995	Socket Housing-15P	
121	1103 0662	Connector-20P	

16. LOWER DC HARNESS (A498)

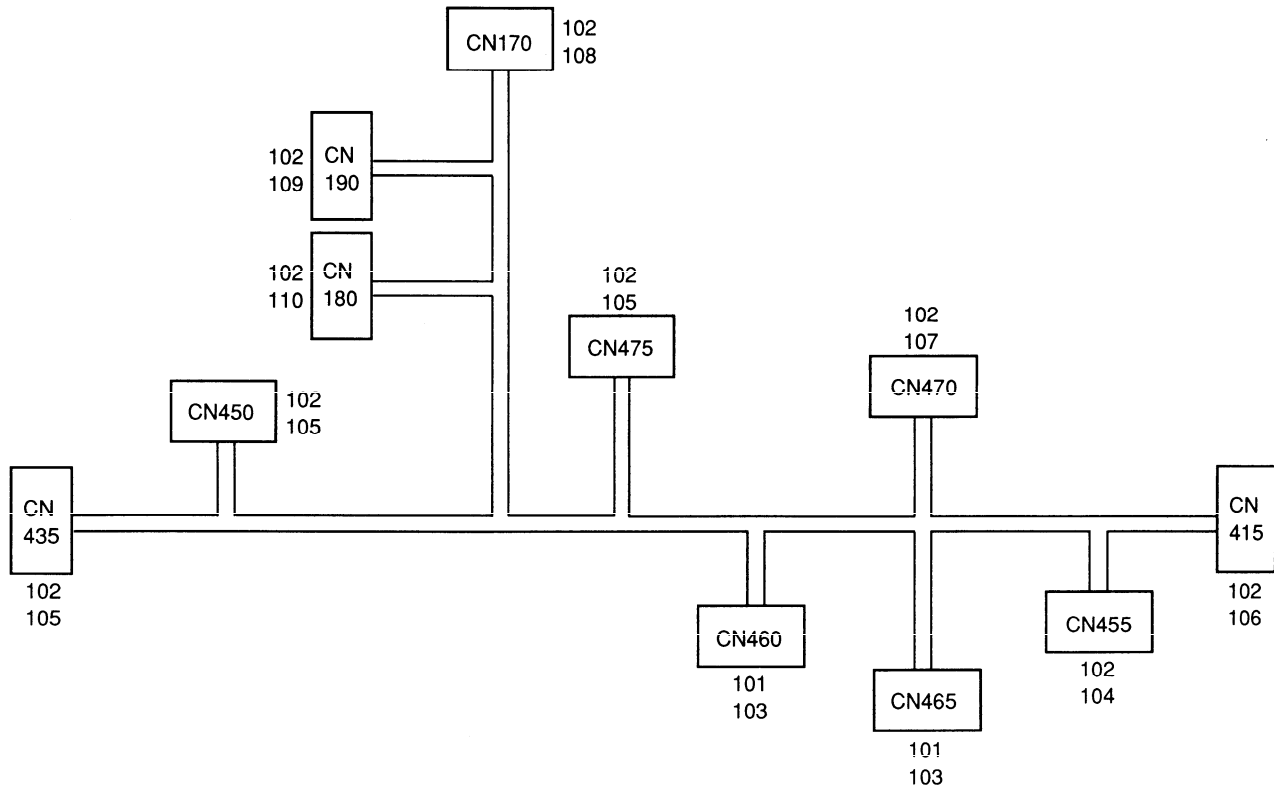

16. LOWER DC HARNESS (A498)

Index No.	Part No.	Description	Q'ty Per Assembly
*	A498 5615	Lower DC Harness	1

Index No.	Part No.	Description	Q'ty Per Assembly
101	1100 1249	Receptacle Terminal	
102	1100 1329	Socket Contact	
103	1102 1620	Connector - 3P	
104	1102 1982	Socket Housing - 2P	
105	1102 1983	Connector - 3P	
106	1102 1984	Connector - 4P	
107	1102 1986	Connector - 6P	
108	1102 1987	Connector 7P	
109	1102 1989	Socket Housing-9P	
110	1102 1990	Socket Housing-10P	

17. GRIPPER HARNESS (A498)

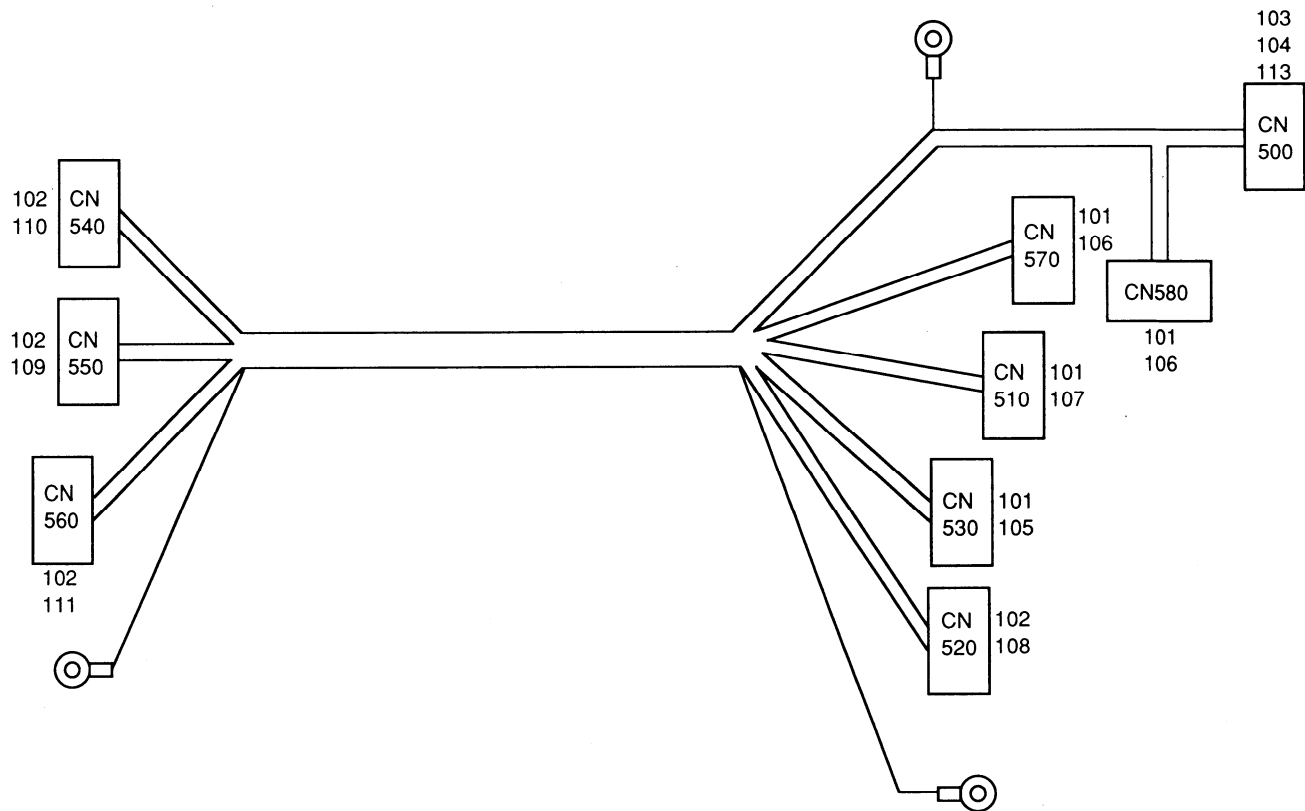

17. GRIPPER HARNESS (A498)

Index No.	Part No.	Description	Q'ty Per Assembly
*	A498 5630	Gripper Harness	1

Index No.	Part No.	Description	Q'ty Per Assembly
101	1100 1329	Socket Contact	
102	1100 1330	Socket Contact	
103	1100 1580	Connector - 1P	
104	1100 1581	Connector - 1P	
105	1102 1982	Socket Housing - 2P	
106	1102 1983	Connector - 3P	
107	1102 1986	Connector - 6P	
108	1102 2025	Pin Housing - 3P	
109	1102 2027	Pin Housing - 6P	
110	1102 2029	Pin Housing - 10P	
111	1102 2030	Pin Housing - 12P	
112	1102 5010	Connector - 12P	

18. DECAL AND DOCUMENT (A498)

1

84 Removing Misted Paper



Press the upper right side release button and open the guide plate



Remove misted paper



If paper cannot be removed, open the inside guide plate and remove misted paper.



Return the guide plate to its original position. Make sure the lock pin is engaged.

2

84 Removing Misted Paper



Press the lower right side release button and open the guide plate



Remove misted paper



Lift the bottom plates and remove misted paper



Press the left side release button and open the guide plate



Remove misted paper



Return the guide plates to their original positions. Make sure the lock pin is engaged.

3

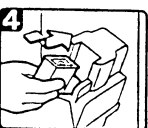
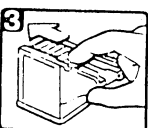
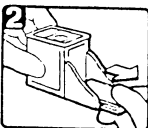
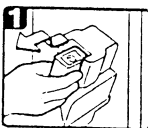

4

DIP SW 100						0	OFF	1	ON	Function
0	0	0	0	0	0					Print Motor Speed Adjustment
1	0	0	0	0	0					Sorter Free Run
0	1	0	0	0	0					Stapler Free Run
1	1	1	0	0	0					Sorter & Stapler Free Run
0	0	1	0	0	0					Lower Stapler Unit (To 600 Bst)
1	0	1	0	0	0					Lower Stapler Unit (To 200 Bst)
0	0	1	1	0	0					Opens Bin Side Plate
0	0	0	0	0	1					Bin/Jam Sensor Adjustment

NOTE: *1
Confirm the setting of DIP SW100-2 to -6 before turning on DIP SW100-1 (Start SW function).
Turn off DIP SW100-1 to stop the function.

5

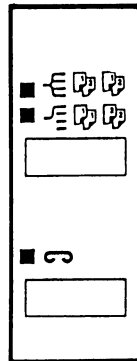

6

How to Set Duplex when a Staple Mode

Set originals face up in a DF. The arrow indicates the position where the copies will be stapled.

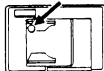

Stapled copies Position of originals in DF

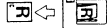
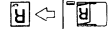
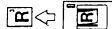

Note *A5.5 x 2" - 8 1/2" or smaller size copies cannot be stapled.
*From 1 to 20 pages can be stapled.

7

OPERATING INSTRUCTIONS

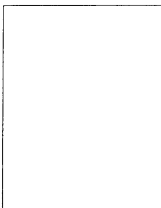

8

INSTALLATION PROCEDURE



18. DECAL AND DOCUMENT (A498)

Index No.	Part No.	Description	Q'ty Per Assembly
1	A498 1801	Decal - Misfeed Removal 1	1
2	A498 1811	Decal - Misfeed Removal 2	1
3	A498 1820	Decal - Staple Replacement	1
4	A498 1841	Decal - Dip Switch	1
5	A498 1831	Staple Position Decal	1
6	A053 5760	Sorter Stapler Panel Sheet - LT	1
6	A053 5763	Sorter Stapler Panel Sheet - A4	1
7	A498 8607	Operating Instructions - English	1
8	A498 8610	Installation Procedure - English	1

Index No.	Part No.	Description	Q'ty Per Assembly

PARTS INDEX

Part No.	Description	Page and Index No.
A498 1061	Lower Hinge Bracket	3- 12
A498 1131	Top Stay Plate	11- 1
A498 1141	Middle Stay	11- 13
A498 1146	Shaft	19- 42
A498 1241	Proof Tray	3- 2
A498 1255	Seal - 10x55x10	3- 21
A498 1270	Exit Cover- Proof Tray	3- 3
A498 1281	Front Door	3- 17
A498 1330	Front Cover	3- 14
A498 1350	Rear Cover	3- 5
A498 1370	Bottom Cover	3- 11
A498 1451	Main Motor Bracket	25- 4
A498 1477	Tightner	25- 18
A498 1485	Tightner Bracket	25- 23
A498 1511	Support Bracket	23- 28
A498 1516	Support Bracket Stay	23- 30
A498 1516	Support Bracket Stay	25- 1
A498 1521	Timing Sensor Bracket	23- 20
A498 1756	Main Motor Cover	11- 11
A498 1760	Upper Hinge Bracket	3- 20
A498 1770	Bottom Cover Bracket	13- 18
A498 1780	Front Door Actuator	3- 16
A498 1791	Front Door Stopper	3- 15
A498 1801	Decal -Misfeed Removal 1	3- 18
A498 1801	Decal -Misfeed Removal 1	37- 1
A498 1811	Decal -Misfeed Removal 2	3-22
A498 1811	Decal-Misfeed Removal 2	37- 2
A498 1820	Decal -Staple Replacement	3- 19
A498 1820	Decal -Staple Replacement	37- 3
A498 1831	Staple Position Decal	37- 5
A498 1841	Decal - Dip Switch	3-23
A498 1841	Decal - Dip Switch	37- 4
A498 2101	Lower Guide Plate - Drive	19- 28
A498 2111	Lower Right Guide	19- 36
A498 2113	Magnet Catch Bracket	7- 22

Part No.	Description	Page and Index No.
A498 2113	Magnet Catch Bracket	19- 30
A498 2114	Bracket - Sorter Entrance Guide	19- 40
A498 2116	Lower Left Guide	19- 29
A498 2118	Seal - 24x11	19- 32
A498 2121	Drive Support Plate	25- 13
A498 2160	Diagonal Transport Plate - Driven	9- 18
A498 2201	Front Side Plate - Diagonal	9- 6
A498 2211	Rear Side Plate - Diagonal	9- 35
A498 2216	Diagonal Transport Plate - Drive	9- 13
A498 2218	Diagonal Transport Stopper	9- 10
A498 2219	Mylar - Diagonal Transport Stopper	9- 25
A498 2240	Support Plate - Transport Roller	9- 32
A498 2242	Tightner	9- 24
A498 2245	Stay Plate	7- 13
A498 2245	Stay Plate	9- 7
A498 2248	Tightner - Diagonal Drive	9- 29
A498 2250	Upper Hinge Bracket	7- 19
A498 2250	Upper Hinge Bracket	9- 22
A498 2255	Lower Hinge Bracket	7- 38
A498 2255	Lower Hinge Bracket	9- 23
A498 2265	Spring Plate	9- 12
A498 2266	Cushion - 8x40	9- 17
A498 2271	Release Button	7- 5
A498 2271	Release Button	9- 2
A498 2271	Release Button	11- 17
A498 2275	Release Button Bracket	7- 3
A498 2275	Release Button Bracket	9- 5
A498 2275	Release Button Bracket	11- 14
A498 2281	Right Release Lever	5- 3
A498 2281	Right Release Lever	9- 14
A498 2285	Release Lever Cover	5- 2
A498 2285	Release Lever Cover	9- 15
A498 2285	Release Lever Cover	11- 34
A498 2298	Support Bracket - Transport Roller	25- 6
A498 2301	Side Plate - Upper Front	7- 8

Part No.	Description	Page and Index No.
A498 2311	Side Plate - Upper Rear	7-30
A498 2327	Vertical Transport Plate	7- 18
A498 2331	Upper Entrance Guide	7- 11
A498 2336	Inner Release Lever	7-40
A498 2343	Lower Entrance Guide	7- 9
A498 2345	Shaft Stay	7- 10
A498 2349	Small Entrance Guide	7-39
A498 2351	Upper Exit Guide	7-29
A498 2356	Vertical Transport Plate-Driven	5- 12
A498 2368	Guide Plate Cushion	5- 4
A498 2371	Bracket - Turn Gate Solenoid	5- 15
A498 2375	Turn Gate Solenoid	5- 14
A498 2380	Turn Gate Lever	5- 10
A498 2383	Turn Gate Rod	5- 11
A498 2386	Magnet	7- 17
A498 2390	Idle Roller	7-36
A498 2401	Turn Gate	5- 6
A498 2410	Front Stopper - Turn Gate	5- 7
A498 2412	Rear Stopper - Turn Gate	5- 8
A498 2420	Horizontal Transport Roller	9- 8
A498 2420	Horizontal Transport Roller	19- 41
A498 2425	Lower Distribution Roller	11- 12
A498 2431	Diagonal Transport Roller	9- 9
A498 2435	Vertical Transport Roller	7- 12
A498 2435	Vertical Transport Roller	9- 11
A498 2440	Exit Roller	7-26
A498 2450	Entrance Driven Roller	9- 19
A498 2455	Diagonal Driven Roller	9-20
A498 2460	Transport Driven Roller	5- 16
A498 2460	Transport Driven Roller	19-37
A498 2465	Exit Driven Roller	7-25
A498 3101	Distribution Transport Frame	11-40
A498 3111	Distribution Guide Plate	11- 28
A498 3113	Spacer - 4.1x6x3.2	11- 21
A498 3116	Release Lever	11-33

Part No.	Description	Page and Index No.
A498 3118	Stepped Screw - M4	11- 36
A498 3121	Bin Gate	11- 6
A498 3132	Solenoid Bracket	23- 16
A498 3141	Upper Hinge Bracket	11- 8
A498 3146	Lower Hinge Bracket	11- 10
A498 3150	Distribution Transport Roller - 433mm	11- 9
A498 3155	Distribution Transport Roller - 368mm	11- 7
A498 3160	Vertical Driven Roller	11- 31
A498 3160	Vertical Driven Roller	19- 35
A498 4100	Jogger Bracket	13- 17
A498 4105	Upper Jogger Bracket	13- 1
A498 4110	Jogger Plate Holder	13- 9
A498 4115	Jogger Holder Seal - 32x41	13- 21
A498 4120	Jogger Holder Roller	13- 10
A498 4135	Rubber Shaft Spacer	13- 11
A498 4140	Jogger Timing Belt Stopper	13- 6
A498 4145	Shoulder Screw - M3	13- 13
A498 4158	Pulley Flange	13- 4
A498 4158	Pulley Flange	13- 25
A498 4160	Pulley Bracket	13- 2
A498 4175	Jogger Plate	13- 16
A498 4178	Plate Cushion	13- 15
A498 4185	Sensor Bracket	13- 23
A498 4310	Motor Bracket	19- 17
A498 4320	Puny Bracket	19- 13
A498 4350	Knob & Pulley - 20Z	19- 21
A498 4360	Knob Tension Bracket	19- 5
A498 4365	Tension Roller	19- 8
A498 4370	Fixing Plate	17-24
A498 4375	Guide Rod - Staple Unit	17- 4
A498 4380	Guide Rod Holder	17- 3
A498 4385	Frame Fixing Bracket	25-26
A498 4390	Front Side Plate	25-25
A498 4510	Stapler Bracket	17- 18
A498 4510	Stapler Bracket	21-36

Part No.	Description	Page and Index No.
A498 4520	Bushing - 18x26x10	17- 15
A498 4525	Bushing Stopper	17- 14
A498 4530	Timing Belt Clamp	17- 5
A498 4535	Stapler Release Lever	17- 7
A498 4540	Connector Shutter	17- 17
A498 4542	Shoulder Screw - M6	17- 19
A498 4542	Shoulder Screw - M6	21-35
A498 4545	Stapler Bracket	21-32
A498 4550	Stapler Fixing Plate	21-31
A498 4555	Stapler Fixing Bracket	21-30
A498 4565	Stapler Connect Holder	21- 29
A498 4575	Gripper Harness Cover	17- 9
A498 4580	Shutter Connect Stopper	17- 10
A498 4585	Connector Cover	17- 23
A498 4588	Flame Connector Cover	17- 1
A498 4590	Lower Entrance Guide - Stapler	17- 20
A498 4595	Stapler Cover	21- 33
A498 4605	Slider Side Plate	21-22
A498 4610	Slider Side Plate - Transport	21- 13
A498 4615	Grip Solenoid	21- 11
A498 4620	Solenoid Link	21- 10
A498 4623	Slider Bushing	21- 15
A498 4625	Arm Cushion	21- 8
A498 4635	Upper Arm Link	21- 4
A498 4640	Upper Gripper Arm	21- 2
A498 4650	Lower Arm Link	21- 7
A498 4655	Lower Gripper Arm	21- 3
A498 4665	Pulley Flange	21- 19
A498 4670	Slider Stopper	21- 14
A498 4675	Slider Shaft Cleaner	21- 16
A498 4685	Sensor Bracket	21- 26
A498 4690	Stapler Entrance Guide	21- 28
A498 4707	Motor Bracket	15- 26
A498 4710	Cam Plate Bracket	15- 21
A498 4720	Plate Guide Cam	15- 16

Part No.	Description	Page and Index No.
A498 4730	Plate Cam	15- 15
A498 4740	Motor Cover	15- 27
A498 4755	Side Plate Lower Bracket	15- 13
A498 4760	Lower Drive Link	15- 10
A498 4765	Upper Drive Link	15- 4
A498 4770	Bin Side Plate	15- 7
A498 4775	Support Link	15- 8
A498 4780	Side Plate Fixing Bracket	15- 6
A498 4810	Sorting Bin	3- 7
A498 4830	Front Bin Holder	3- 13
A498 4835	Harness Guide	3- 4
A498 4840	Upper Exit Guide	13- 3
A498 4845	Upper Exit Guide - Small	11- 3
A498 4850	Middle Exit Guide	3- 8
A498 4860	Grounding Plate	3- 10
A498 5100	Main Control Board	23- 31
A498 5100	Main Control Board	27- *
A498 5103	IC - HN27256G-25	27- 1
A498 5210	Bracket - Front Door Switch	11- 27
A498 5240	Front Door Switch - AC	11- 23
A498 5250	Front Door Switch - DC	11- 25
A498 5260	Insulating Sheet	11- 24
A498 5400	Bin Solenoid	23- 17
A498 5600	AC Harness	23- 22
A498 5600	AC Harness	29- *
A498 5610	Upper DC Harness	19- 23
A498 5610	Upper DC Harness	23- 23
A498 5610	Upper DC Harness	31- *
A498 5615	Lower DC Harness	19- 24
A498 5615	Lower DC Harness	23- 21
A498 5615	Lower DC Harness	33- *
A498 5620	Paper Sensor Harness	21- 23
A498 5630	Gripper Harness	17- 2
A498 5630	Gripper Harness	35- *
A498 5640	Harness - Sorter Entrance Sensor	19- 38

Part No.	Description	Page and Index No.
A498 5650	Harness - Upper Bin/Jam Sensor	11- 5
A498 5660	Harness - Proof Sensor	7- 16
A498 6050	Front Connecting Bracket	3-24
A498 6055	Rear Connecting Bracket	3-25
A498 6060	Locking Bracket	3-26
A498 6070	Upper Entrance Guide Mylar	3-27
A498 6075	Lower Entrance Guide Mylar	3-28
A498 6085	Caster Stopper	25- 14
A498 8607	Operating Instructions - English	37- 7
A498 8610	Installation Procedure - English	37- 8

Part No.	Description	Page and Index No.
AA02 0003	Slide Lever Magnet	7- 2
AA02 0003	Slide Lever Magnet	19- 27
AA04 3081	Timing Belt - 489P3M6	25- 17
AA04 3090	Timing Belt - 330P3M6	25- 8
AA04 3091	Timing Belt -861P3M6	7- 33
AA04 3091	Timing Belt -861P3M6	23- 24
AA04 3093	Timing Belt - 825P3M6	9-31
AA04 3094	Timing Belt - 6x144	19- 3
AA04 3095	Timing Belt - 10x1788	17- 6
AA04 3096	Timing Belt - 4x160	19- 20
AA04 3097	Timing Belt - 4x580	13- 7
AA04 3098	Timing Belt - 4x190	21- 18
AA06 0273	Turn Gate Spring	5- 9
AA06 0274	Solenoid Spring	21- 9
AA06 0275	Arm Spring	21- 6
AA06 6111	Release Button Spring	7- 4
AA06 6111	Release Button Spring	9- 3
AA06 6111	Release Button Spring	11- 15
AA06 6112	Spring	7-23
AA06 6113	Release Lever Spring	17- 8
AA06 6114	Shutter Stopper Spring	17- 11
AA06 6115	Cam Support Spring	15- 14
AA06 6116	Side Fence Spring	15- 12
AA06 61 20	Lower Jogger Spring	13- 14
AA06 6121	Upper Jogger Spring	13- 12
AA08 0071	Bushing - 6x10X6	9- 1
AA08 0071	Bushing - 6x10X6	11- 19
AA08 0071	Bushing - 6x10X6	23- 6
AA08 0071	Bushing - 6x10X6	25-22
AA08 0072	Bushing - 6x10x3	15- 1
AA08 0074	Bushing - 4x6x6	21- 17
AA12 0027	Antistatic Brush	7-21
AA12 0027	Antistatic Brush	11- 2
AA12 0027	Antistatic Brush	19- 26
AA12 0028	Antistatic Brush	3- 6

Part No.	Description	Page and Index No.
AA14 0303	Jogger Slide Shaft	13- 8
AA14 0304	Jogger Pulley Shaft	13-24
AA14 0305	Slider Shaft	21- 12
AA14 5030	Knob Tension Shaft	19- 12
AA14 5122	Release Button Shaft	7- 1
AA14 5122	Release Button Shaft	9- 4
AA14 5122	Release Button Shaft	11- 16
AA14 5123	Connector Shutter Shaft	17- 16
AA14 5124	Shutter Stopper Spring	17- 12
AA14 5125	Inner Side Fence Shaft	15- 3
AA14 5126	Lower Side Fence Shaft	15- 11
AA14 5127	Upper Side Fence Shaft	15- 5
AA14 8235	Warm Gear Shaft	19- 14
AA14 8236	Upper Pulley Shaft	19- 6
AA14 8237	Lower Pulley Shaft	19- 11
AA14 8238	Side Fence Shaft	15- 18
AA14 8239	Drive Cam Shaft	15- 23
AB01 0046	Gear - 36Z	9-27
AB01 0047	Gear - 72Z	15- 22
AB01 7170	Idle Gear 36Z/24Z	9-26
AB01 7171	Gear And Pulley - 50Z/14Z	7-37
AB01 7172	Double Gear - 20/72Z	15-24
AB03 0029	Pulley - 20T	9-34
AB03 0029	Pulley - 20T	25-21
AB03 0030	Pulley - 17T	23- 7
AB03 0072	Pulley - 31Z	7- 35
AB03 0072	Pulley - 31Z	19- 7
AB03 0073	Pulley - 31Z	7-34
AB03 0201	Pulley - 24Z	9-33
AB03 0203	Pulley - 26Z	9-36
AB03 0205	Pulley - 31Z	7-31
AB03 0207	Idle Gear - 20Z	23- 9
AB03 0209	Pulley - 20Z	19- 10
AB03 0211	Pulley - 20Z	19- 2
AB03 0212	Pulley - 15Z	19- 4

Part No.	Description	Page and Index No.
AB03 0213	Pulley -362	13- 19
AB03 0215	Pulley -362	13- 5
AB03 0215	Pulley -362	13-26
AB03 0216	Pulley -152	21-21
AB03 0218	Pulley -152	21-20
AB03 0219	Pulley - 30Z	19- 15
AB03 3027	Pulley - 15/18Z	25- 7
AJ01 1002	Stapler Unit	21-34
AW02 0006	Photointerruptor - EE-SX460-P2	15-20
AW02 0007	Photointerruptor - ON1531A2-(A)4	19-22
AW02 0013	Inlet Sensor	7- 14
AW02 0013	Inlet Sensor	19-39
AW02 0014	Photo Sensor	17-22
AW02 0014	Photo Sensor	21- 25
AW02 0025	Lower Bin/Jam Sensor	11- 4
AW02 0026	Upper Bin/Jam Sensor	19-25
AW03 0014	Fiber Cable -800	23-26
AX02 0052	Main Motor	25- 3
AX04 0025	Staple Unit Motor	19- 1
AX04 0034	Motor - DC 2.2W	15-25
AX04 0035	Motor - DC 2.4W	21-24
AX04 0036	Motor - DC 8.16W	13-20
A007 1848	Guide Rod Cleaner	17- 13
A010 5700	Sensor	21-27
A053 5760	Sorter Stapler Panel Sheet - LT	37- 6
A053 5763	Sorter Stapler Panel Sheet - A4	37- 6
A366 6090	Fixing Bracket	3-29
A422 5310	Feed-out Motor - DC10W	7- 15
A458 1231	Stud	25- 12
A458 1522	Rear Bin Holder	3- 9
A458 1561	Holding Plate And Bearing - 6x12x4	23- 2
A458 1561	Holding Plate And Bearing - 6x12x4	25- 9
A458 2161	Bushing - 6x8x6	7- 24
A458 2161	Bushing - 6x8x6	11-30
A458 2161	Bushing - 6x8x6	19-33

Part No.	Description	Page and Index No.
A458 2165	Spring - Driven Roller	7-27
A458 2165	Spring - Driven Roller	11- 32
A458 2165	Spring - Driven Roller	19- 34
A458 2232	Bin Solenoid Lever	23- 13
A458 2251	Cushion - Bin Solenoid Lever	23- 12
A458 3121	Pulley - 50Z	25- 11
A458 3132	Pulley - 17Z	23- 3
A458 3132	Pulley - 17Z	25- 10
A458 3141	Pulley - 39Z	23-29
A458 3142	Pulley - 39Z	23-25
A458 3151	Pulley - 17/50Z	25- 15
A458 3211	Tightner	23- 27
A458 3221	tightner	25-20
A458 3231	tightner	23- 8
A458 3431	timing Belt-699P3M6	23- 15
A469 3280	Board Support Bracket -Short	23- 1
A469 3350	Guide Stud	11-29
A469 4103	Worm Gear-2Z	19- 16
A469 4104	Gear-25Z	19- 9
A469 4465	Reverse Roller	15- 2
A469 5130	Bin Solenoid Board	23- 18
A469 5350	Motor Damper	19- 18
A469 5465	Grounding Wire	19- 19
A469 5465	Grounding Wire	25- 2
C201 5125	Shoulder Screw - M4	21- 5
5053 0223	Bushing - 8mm	15- 17
5053 0447	Bushing - 6mm	5- 5
5053 0447	Bushing - 6mm	7- 7
5053 0447	Bushing - 6mm	15- 19
5054 0536	Magnet Catch Ass'y	11-26
5056 0509	Nut Plate - Microswitch	11-22
5203 1091	Collar	15- 9
5203 1091	Collar	17-21
5214 1811	Idle Pulley - 20Z	9-28
5215 3860	Cushion	25-27

Part No.	Description	Page and Index No.
5216 5245	Photointerruptor - IL-G-3P-S3T2-E	13- 22
5216 5245	Photointerruptor - IL-G-3P-S3T2-E	23- 19
5316 3062	Cushion - Cutter	3- 1
5353 4258	Screw - Slider	21- 1
5403 2075	Stepped Screw	7- 6
5403 2075	Stepped Screw	9-30
5403 2075	Stepped Screw	11- 20
5403 2075	Stepped Screw	23- 10
5403 6246	Stepped Screw - Cleaning	11- 38
5403 6246	Stepped Screw - Cleaning	25- 24
5410 1291	Return Lever Pin	7- 28
5410 1291	Return Lever Pin	19- 31
5420 1087	Perforation Disk	25- 16
5442 4495	Slip Clutch	7- 32
5447 2681	Snap Ring	5- 13
5447 2681	Snap Ring	7- 20
5447 2681	Snap Ring	9- 21
5447 2681	Snap Ring	11- 37
5840 2416	Bushing - Pinch Roller	11- 18
5840 2416	Bushing - Pinch Roller	23- 11
5875 2088	Shoulder Screw - M4	5- 1
5875 2088	Shoulder Screw - M4	9- 16
5875 2088	Shoulder Screw - M4	11- 35
5887 4166	Return Spring - Turn Pawl	23- 14
5887 4167	Holder Spring - Turn Pawl	23- 32
5887 4185	Idler Pulley	23- 4
5887 4185	Idler Pulley	25- 19
5887 4195	Stopper Screw	23- 5
5937 2114	Bushing - Driving Side Plate	11-39
5937 2114	Bushing - Driving Side Plate	25- 5

Part No.	Description	Page and Index No.
0313 0050W	Philips Pan Head Screw - M3x5	5-103
0313 0050W	Philips Pan Head Screw - M3x5	7-103
0313 0050W	Philips Pan Head Screw - M3x5	21-105
0313 0050W	Philips Pan Head Screw - M3x5	23-103
0313 0060W	Philips Pan Head Screw - M3x6	23-121
0313 0100W	Philips Pan Head Screw - M3x10	17-103
0313 0100W	Philips Pan Head Screw - M3x10	21-106
0313 0160W	Philips Pan Head Screw - M3x16	11-103
0313 0160W	Philips Pan Head Screw - M3x16	19-103
0314 0060W	Philips Pan Head Screw - M4x6	3-104
0314 0060W	Philips Pan Head Screw - M4x6	5-101
0314 0060W	Philips Pan Head Screw - M4x6	7-101
0314 0060W	Philips Pan Head Screw - M4x6	9-101
0314 0060W	Philips Pan Head Screw - M4x6	11-101
0314 0060W	Philips Pan Head Screw - M4x6	13-101
0314 0060W	Philips Pan Head Screw - M4x6	15-101
0314 0060W	Philips Pan Head Screw - M4x6	17-101
0314 0060W	Philips Pan Head Screw - M4x6	19-102
0314 0060W	Philips Pan Head Screw - M4x6	21-101
0314 0060W	Philips Pan Head Screw - M4x6	23-102
0314 0060W	Philips Pan Head Screw - M4x6	25-101
0314 0080W	Philips Pan Head Screw - M4x8	19-101
0314 0080W	Philips Pan Head Screw - M4x8	25-102
0314 0100W	Philips Pan Head Screw - M4x10	19-119
0314 0100W	Philips Pan Head Screw - M4x10	21-108
0315 0080W	Philips Pan Head Screw - M5x8	25-108
0323 0050B	Screw - M3x5	5-102
0344 0080F	Philips Truss Head Screw - M4x8	3-101
0344 0080F	Philips Truss Head Screw - M4x8	21-102
0344 0120F	Philips Truss Head Screw - M4x12	3-105
0353 0040F	Philips Pan Head Bind Screw - M3x4	7-109
0433 0064W	Tapping Screw - M3x6	19-104
0434 0060W	Tapping Screw - M4x6	17-108
0434 0102W	Tapping Screw - M4x10	19-105
0573 0040E	Hexagon Headless Set Screw - M3x4	23-120

Part No.	Description	Page and Index No.
0574 0040E	Hexagon Headless Set Screw - M4x4	7-108
0574 0040E	Hexagon Headless Set Screw - M4x4	9-105
0574 0040E	Hexagon Headless Set Screw - M4x4	13-106
0574 0040E	Hexagon Headless Set Screw - M4x4	15-107
0574 0040E	Hexagon Headless Set Screw - M4x4	19-107
0574 0040E	Hexagon Headless Set Screw - M4x4	19-109
0574 0040E	Hexagon Headless Set Screw - M4x4	21-114
0574 0040E	Hexagon Headless Set Screw - M4x4	23-115
0574 0040E	Hexagon Headless Set Screw - M4x4	25-105
0574 0060E	Hexagon Headless Set Screw - M4x6	19-108
0574 0060E	Hexagon Headless Set Screw - M4x6	25-104
0575 0060E	Hexagon Headless Set Screw - M5x6	25-112
0623 0120E	Spring Pin - 3x12mm	21-111
0632 0140G	Parallel Pin	15-108
0632 0140G	Parallel Pin	19-112
0632 0160G	Parallel Pin - M2x16	13-108
0701 0030G	Flat Washer - M3	11-108
0701 0060W	Flat Washer - M6	7-107
0720 0030E	Retaining Ring - M3	5-106
0720 0030E	Retaining Ring - M3	7-105
0720 0030E	Retaining Ring - M3	11-105
0720 0030E	Retaining Ring - M3	13-105
0720 0030E	Retaining Ring - M3	15-105
0720 0030E	Retaining Ring - M3	17-105
0720 0030E	Retaining Ring - M3	19-114
0720 0030E	Retaining Ring - M3	21-112
0720 0040E	Retaining Ring - M4	5-105
0720 0040E	Retaining Ring - M4	7-104
0720 0040E	Retaining Ring - M4	9-104
0720 0040E	Retaining Ring - M4	11-106
0720 0040E	Retaining Ring - M4	13-107
0720 0040E	Retaining Ring - M4	15-104
0720 0040E	Retaining Ring - M4	17-106
0720 0040E	Retaining Ring - M4	19-110
0720 0040E	Retaining Ring - M4	21-113

Part No.	Description	Page and Index No.
0720 0040E	Retaining Ring - M4	23-114
0720 0040E	Retaining Ring - M4	25-106
0720 0060E	Retaining Ring - M6	13-104
0720 0060E	Retaining Ring - M6	15-106
0720 0060E	Retaining Ring - M6	19-111
0720 0060E	Retaining Ring - M6	23-117
0720 0060E	Retaining Ring - M6	25-107
0800 0072	Philips Pan Head Screw -M2.6x4	15-103
0801 1185	Philips Truss Head Screw -M4x8	23-104
0805 3145	Ball Bearing - 6x12x4mm	9-106
0805 3145	Ball Bearing -6x12x4mm	19-116
0805 3145	Ball Bearing -6x12x4mm	23-119
0805 3291	Ball Bearing -8x16x5mm	19-117
0805 3386	Bushing-8mm	13-109
0805 3386	Bushing-8mm	19-118
0805 5003	Caster	25-111
0951 3005W	Philips Screw with FlatWasher-M3x5	9-102
0951 3006W	Philips Screw With FlatWasher-M3x6	21-109
0951 3008W	Philips Screw with FlatWasher-M3x8	21-104
0951 3014W	Philips Screw With Flat Washer - M3	21-110
0951 3030W	Philips Screw With Washer - M3x30	11-104
0951 4006W	Philips Screw With Flat Washer - M4x6	3-103
0951 4006W	Philips Screw With Flat Washer - M4x6	5-104
0951 4006W	Philips Screw With Flat Washer - M4x6	7-102
0951 4006W	Philips Screw With Flat Washer - M4x6	9-103
0951 4006W	Philips Screw With Flat Washer - M4x6	11-102
0951 4006W	Philips Screw With Flat Washer - M4x6	13-102
0951 4006W	Philips Screw With Flat Washer - M4x6	15-102
0951 4006W	Philips Screw With Flat Washer - M4x6	17-104
0951 4006W	Philips Screw With Flat Washer - M4x6	19-106
0951 4006W	Philips Screw With Flat Washer - M4x6	21-103
0951 4006W	Philips Screw With Flat Washer - M4x6	23-101
0951 4006W	Philips Screw With Flat Washer - M4x6	25-103
0951 4008W	Philips Screw With Flat Washer - M4x8	3-102
0951 4008W	Philips Screw With Flat Washer - M4x8	13-103

Part No.	Description	Page and Index No.
0951 4008W	Philips Screw With Flat Washer - M4x8	17-102
1100 1239	Pin - Mate-N-Lock	29-101
1100 1239	Pin - Mate-N-Lock	31-101
1100 1241	Socket - Mate-N-Lock	29-102
1100 1241	Socket - Mate-N-Lock	31-102
1100 1247	Terminal	29-103
1100 1247	Terminal	31-103
1100 1249	Receptacle Terminal	33-101
1100 1259	Socket - Mate-N-Lock	31-104
1100 1329	Socket Contact	31-105
1100 1329	Socket Contact	33-102
1100 1329	Socket Contact	35-101
1100 1330	Socket Contact	35-102
1100 1348	Pin Contact	31-106
1100 1580	Connector -1P	35-103
1100 1581	Connector -1P	35-104
1101 0328	Connector Pin Contact	27-101
1102 1089	Connector - 3P	31-107
1102 1507	Connector - 2P	31-108
1102 1515	Connector - 2P	29-104
1102 1517	Connector - 4P	31-109
1102 1524	Connector - 2P	29-105
1102 1620	Connector - 3P	33-103
1102 1831	Connector - 4P	31-110
1102 1896	Connector - 2P	29-106
1102 1982	Socket Housing - 2P	31-111
1102 1982	Socket Housing - 2P	33-104
1102 1982	Socket Housing - 2P	35-105
1102 1983	Connector - 3P	33-105
1102 1983	Connector - 3P	35-106
1102 1984	Connector - 4P	31-112
1102 1984	Connector - 4P	33-106
1102 1985	Connector - 5P	31-113
1102 1986	Connector - 6P	31-114
1102 1986	Connector - 6P	33-107

Part No.	Description	Page and Index No.
1102 1986	Connector - 6P	35-107
1102 1987	Connector 7P	33-108
1102 1988	Socket Housing - 8P	31-115
1102 1989	Socket Housing - 9P	33-109
1102 1990	Socket Housing - 10P	31-116
1102 1990	Socket Housing - 10P	33-110
1102 1991	Socket Housing - 11P	31-117
1102 1992	Socket Housing - 12P	31-118
1102 1994	Socket Housing - 14P	31-119
1102 1995	Socket Housing - 15P	31-120
1102 2025	Pin Housing - 3P	35-108
1102 2027	Pin Housing - 6P	35-109
1102 2029	Pin Housing - 10P	35-110
1102 2030	Pin Housing - 12P	35-111
1102 5003	Connector - 2P	27-102
1102 5010	Connector - 12P	35-112
1103 0441	Connector - 4P	27-103
1103 0662	Connector - 20P	31-121
1103 0750	Pin Housing - 2P	27-104
1103 1770	Connector - 4P	27-105
1103 1771	Connector - 5P	27-106
1103 1772	Pin Header - 6P	27-107
1103 1773	Pin Header - 7P	27-108
1103 1775	Pin Header - 9P	27-109
1103 1776	Pin Header - 10P	27-110
1103 1780	Connector - 14P	27-111
1103 1781	Pin Header- 15P (Brown)	27-112
1103 3020	Connector-20P	27-113
1104 0588	DIP Socket-28P	27-114
1105 0005	NylonClip-3N	23-111
1105 0008	NylonClip-2N	11-107
1105 0008	NylonClip-2N	15-109
1105 0008	NylonClip-2N	23-113
1105 0009	NylonClip-5N	23-112
1105 0010	Nylon Clip - 6N	17-110

Part No.	Description	Page and Index No.
1105 0016	Nylon Clip - 4N	23-109
1105 0134	Locking Support	23-118
1105 0161	Locking Support	23-116
1105 0196	Harness Clamp	7-106
1105 0196	Harness Clamp	17-109
1105 0196	Harness Clamp	23-108
1105 0196	Harness Clamp	25-110
1105 0197	Wire Saddle	19-113
1105 0197	Wire Saddle	23-107
1105 0197	Wire Saddle	25-109
1105 0200	Clamp	21-107
1106 0310	Bushing	19-115
1106 0310	Bushing	23-105
1106 0411	Bushing -11.5mm	17-107
1106 0411	Bushing -11.5mm	23-106
1106 0459	Bushing - 20.2mm	23-110
1204 1570	Dip Switch	27-115
1208 1258	Solid State Relay - AC240V	27-116
1401 0234	Transistor - 2SD686	27-117
1401 0802	Diode - RD24FB	27-118
1402 0642	Zener Diode - RD8.2M-B1	27-119
1402 0780	Diode -11ES2	27-120
1403 0238	IC - TLP521	27-121
1403 0669	Red LED - SLM-13VW	27-122
1407 1306	IC - SN74LS00	27-123
1407 1314	IC - HD74LS74AFP	27-124
1407 1882	IC - SN74LS373NS	27-125
1407 2055	IC - TD62304F	27-126
1407 2057	IC - 82C55AFP-5	27-127
1407 2073	IC -µPD78C10GF	27-128
1407 2218	IC - SN74LS06NS	27-129
1407 2231	IC - TD62308AF	27-130
1407 3055	IC - HD74LS158FP	27-131
1407 3286	IC - TC74HC04AF	27-132
1408 0408	IC - PST518A	27-133

Part No.	Description	Page and Index No.
1408 0599	IC - M51971EP	27-134
1408 0604	IC - μ PC393	27-135
1408 0839	IC - STK6712 BMK3	27-136
1408 0840	IC - HR052	27-137
1503 0071	Oscillator - 12MHz	27-138
1601 7352	Resistor Array - 4.7k OHM	27-139
1601 7358	Resistor Array - 47K OHM	27-140
1601 7374	Resistor Array - 4.7K OHM	27-141
1601 8148	Variable Resistor - 20k OHM 0.5W	27-142
1601 8185	Variable Resistor -200 OHM 0.5W	27-143
1602 0934	RC Array - CR01 -R	27-144
1604 1357	Capacitor - 470 μ F, 10V	27-145
1604 1362	Capacitor - 4.7 μ F 25V	27-146
1604 1378	Capacitor - 1 μ F 50V	27-147
1604 1379	Capacitor - 2.2 μ F \pm 20% 50V	27-148
1604 1380	Capacitor - 3.3 μ F 50V	27-149
1604 1389	Capacitor - 470 μ F 50V	27-150
1605 0145	Capacitor - 30pF 50V	27-151
1605 0221	Capacitor - 0.022 μ F 50V	27-152
1606 1451	Capacitor - 0.1 μ F 50V	27-153
1606 1452	Capacitor - 0.01 μ F 50V	27-154
1611 4102	Resistor -1K OHM 1/4T \pm 5%	27-155
1630 2101	Resistor -100 OHM 1/8W	27-156
1630 2102	Resistor -1K OHM 1/8W \pm 5%	27-157
1630 2103	Resistor - 10K OHM 1/8W	27-158
1630 2122	Resistor - 1.2K OHM 1/8W \pm 5%	27-159
1630 2151	Resistor - 1.5K OHM 1/8W \pm 5%	27-160
1630 2202	Resistor - 2K OHM 1/8W \pm 5%	27-161
1630 2223	Resistor - 22K OHM 1/8W \pm 5%	27-162
1630 2229	Resistor -240 OHM 1/8W \pm 5%	27-163
1630 2241	Resistor -240 OHM	27-164
1630 2332	Resistor - 3.3k OHM 1/8W \pm 5%	27-165
1630 2391	Resistor -390 OHM 1/8W	27-166
1630 2472	Resistor - 4.7K OHM 1/8W \pm 5%	27-167
1630 2473	Resistor - 47K OHM 1/8W \pm 5%	27-168

Part No.	Description	Page and Index No.
1630 2511	Resistor -510 OHM 1/8W \pm 5%	27-169
1630 2682	Resistor - 6.8K OHM 1/8W \pm 5%	27-170